

BALDOR® • RELIANCE

Product Information Packet

FDL3514TM

1.5HP, 1725RPM, 1PH, 60HZ, 145T, 3532LC, TEFC

Copyright © All product information within this document is subject to Baldor Electric Company copyright © protection, unless otherwise noted.

Part Detail							
Revision:	C	Status:	PRD/A	Change #:		Proprietary:	No
Type:	AC	Prod. Type:	3532LC	Elec. Spec:	35WGN451	CD Diagram:	
Enclosure:	TEFC	Mfg Plant:		Mech. Spec:	35KK717	Layout:	
Frame:	145T	Mounting:	F1	Poles:	04	Created Date:	04-02-2012
Base:	RG	Rotation:	R	Insulation:	B	Eff. Date:	10-09-2012
Leads:	4#16 A&J,2#18 B PH,1#	Literature:		Elec. Diagram:		Replaced By:	

Nameplate NP1280L							
CAT.NO.	FDL3514TM						
SPEC.	35KK717N451						
HP	1.5						
VOLTS	115/208-230						
AMP	12.4/6.8-6.2						
RPM	1725						
FRAME	145T	HZ	60	PH	1		
SER.F.	1.00	CODE	J	DES	L	CL	B
NEMA-NOM-EFF	80	PF	96				
RATING	40C AMB-CONT						
CC				USABLE AT 208V			
DE	6205	ODE	6203				
ENCL	TEFC	SN					

Parts List		
Part Number	Description	Quantity
SA241952	SA 35KK717N451	1.000 EA
RA228868	RA 35KK717N451	1.000 EA
OC3060C09	CYL OIL CAP 60MFD/240V	1.000 EA
TPCRD3707	THERMAL 1PH 1.00 MAN SPL LOW TEMP WELD	1.000 EA
EC1540A04	ELEC CAP, 540-648 MFD, 125V, 1.81D X 4.	1.000 EA
WD3006A01	RSS-2-103JT 2W 10K RES. METAL OXIDE 5%	1.000 EA
TP5059	GENERIC THERMAL KIT	1.000 EA
NS2512A01	INSULATOR, CONDUIT BOX X	1.000 EA
35CB3009A17	35 CB 1.09 DIA @ 6:00, 1.00 MTO @ 3:00	1.000 EA
36GS1000SP	GASKET-CONDUIT BOX, .06 THICK #SV-330 LE	1.000 EA
51XB1016A07	10-16 X 7/16 HXWSSLD SERTYB	2.000 EA
HA6015A11	EARED 1" THERMAL RETAINER (PLATED)	1.000 EA
RM1014A01SP	BUTYL RUB.THRM COV. (MENA)	1.000 EA
NS2500A02	INSULATOR, MAN THER PROT	1.000 EA
51XB1214A10	12-14 X 5/8HX WS SL SR TYBX	2.000 EA
11XW1032G06	10-32 X .38, TAPTITE II, HEX WSHR SLTD U	1.000 EA
35EP3100M01	FREP TEFC 203 BRG W/GRSR (RAISED FH PADS	1.000 EA
HW4500A01	1641B(ALEMITE)400 UNIV, GREASE FITT	1.000 EA
51XW0832A07	8-32 X .44, TAPTITE II, HEX WSHR SLTD SE	2.000 EA
35CB3801SP	CAPACITOR COVER, CAST	1.000 EA
34GS3002	GASKET, CAPACITOR BOX	1.000 EA
HA7010	CAPACITOR RETENTION CLAMP	1.000 EA
NS2501A02	INSULATOR, CAPACITOR BOX	1.000 EA
51XB1016A08	10-16X 1/2HXWSSLD SERTYB	2.000 EA

Parts List (continued)		
Part Number	Description	Quantity
HW5100A03SP	WAVY WASHER (W1543-017)	1.000 EA
35EP3101A01SP	STD PU EP-ENCLOSED-205 BRG-W/GREASER	1.000 EA
HW4500A01	1641B(ALEMITE)400 UNIV, GREASE FITT	1.000 EA
XY1032A02	10-32 HEX NUT DIRECTIONAL SERRATION	4.000 EA
51XB1214A16	12-14X1.00 HXWSSLD SERTYB	1.000 EA
35FH4005A84SP	IEC FH W/GRSR, NO DIMPLES W/AUTOPHERETIC	1.000 EA
51XW1032A06	10-32 X .38, TAPTITE II, HEX WSHR SLTD S	3.000 EA
35CB4521GX	CONDUIT BOX LID KIT	1.000 EA
51XW0832A07	8-32 X .44, TAPTITE II, HEX WSHR SLTD SE	4.000 EA
HW2501D13SP	KEY, 3/16 SQ X 1.375	1.000 EA
HA7000A01	KEY RETAINER 7/8" DIA SHAFT	1.000 EA
85XU0407S04	4X1/4 U DRIVE PIN STAINLESS	2.000 EA
LB1087	LABEL,MANUAL RESET (ROLL LABEL)	1.000 EA
MJ1000A75	GREASE, POLYREX EM EXXON	0.050 LB
35FN3002A05SP	EXFN, PLASTIC, 6.376 OD, .638 ID	1.000 EA
MG1025Z20	ACTIVATOR WILKOFASST 060.32	0.010 GA
MG1025C02	PAINT, 787.105 LITE TAN EPOXY (USE W/MG1	0.017 GA
HA3100A22	THRUBOLT 10-32 X 10.125	4.000 EA
SP5181A01	MODEL 35 LC TORQ STAT SWITCH LEAD ASSY	1.000 EA
WD1000A15	3-520132-2 AMP FLAG (4M/RL NON-CANC/NON-	4.000 EA
LB1119	WARNING LABEL	1.000 EA
LB1172A01	CUSTOM MTR CARTON LABEL LASER PRINTER	1.000 EA
LC0269	1PH,DV,REV,THERMAL,7 LD,L.AMP THRU HTR H	1.000 EA
NP1280L	ALUM FARM DUTY UL CSA CC THERMAL	1.000 EA

Parts List (continued)		
Part Number	Description	Quantity
36PA1000	PACK GROUP W/LB5001	1.000 EA

Accessories		
Part Number	Description	Multiplier
35-8762	C FACE KIT	A8
35EP1506A01SP	D-FLANGE KIT	A8

Performance Data at 230V, 60Hz, 1.5HP (Typical performance - Not guaranteed values)

General Characteristics							
Full Load Torque:	4.48 LB-FT			Start Configuration:	DOL		
No-Load Current:	1.76 Amps			Break-Down Torque:	12.1 LB-FT		
Line-line Res. @ 25°C.:	1.69 Ohms A Ph / 1.5344 Ohms B Ph			Pull-Up Torque:	8.43 LB-FT		
Temp. Rise @ Rated Load:	69 C			Locked-Rotor Torque:	13.8 LB-FT		
Temp. Rise @ S.F. Load:				Starting Current:	49.5 Amps		
Load Characteristics							
% of Rated Load	25	50	75	100	125	150	S.F.
Power Factor:	83.0	91.0	95.0	96.0	96.0	96.0	0.0
Efficiency:	58.3	74.3	79.3	81.2	80.3	77.8	0.0
Speed:	1786.8	1773.6	1758.8	1742.3	1721.1	1696.6	0.0
Line Amperes:	2.41	3.53	4.78	6.21	7.86	9.72	0.0

Performance Graph at 230V, 60Hz, 1.5HP Typical performance - Not guaranteed values

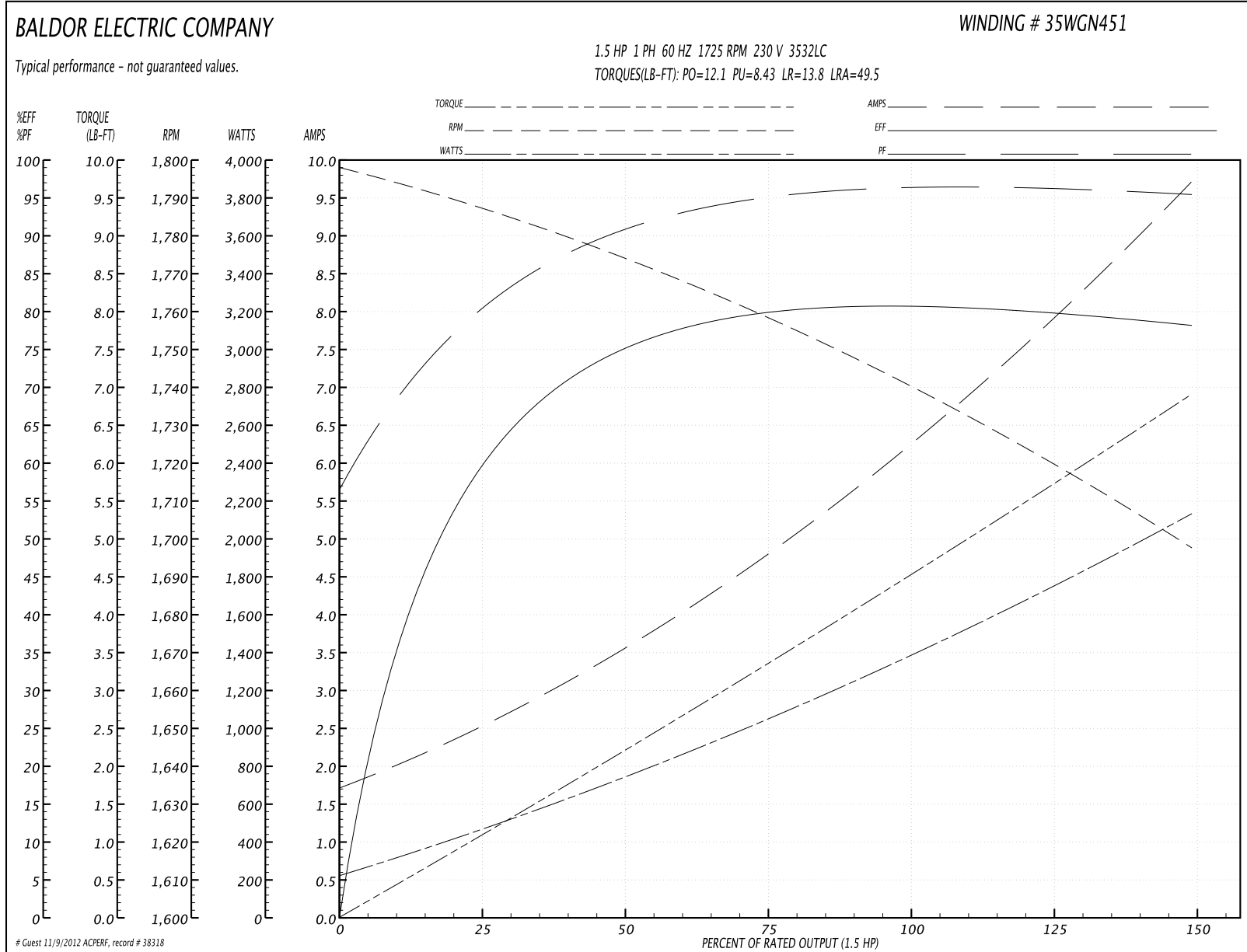

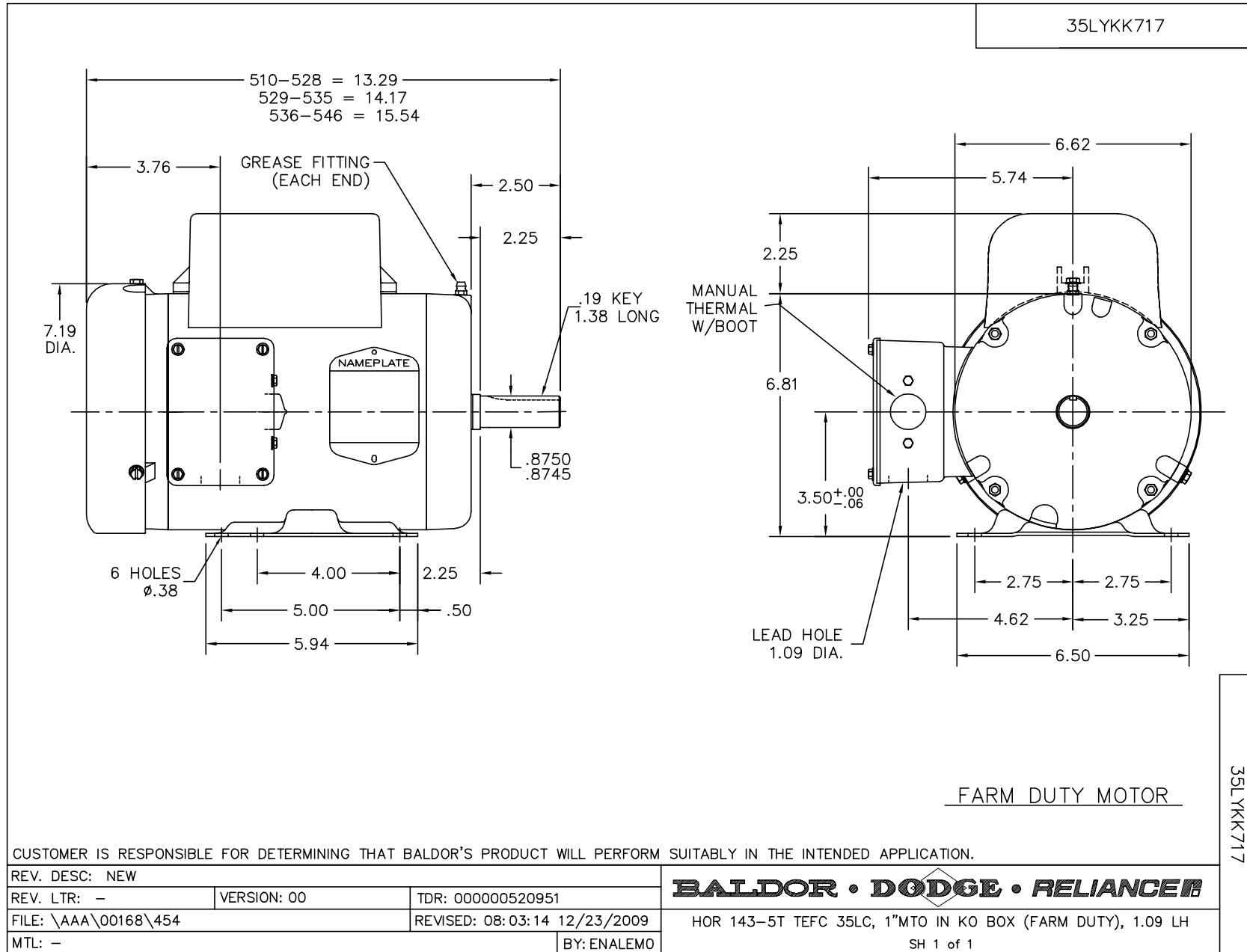

CD0320

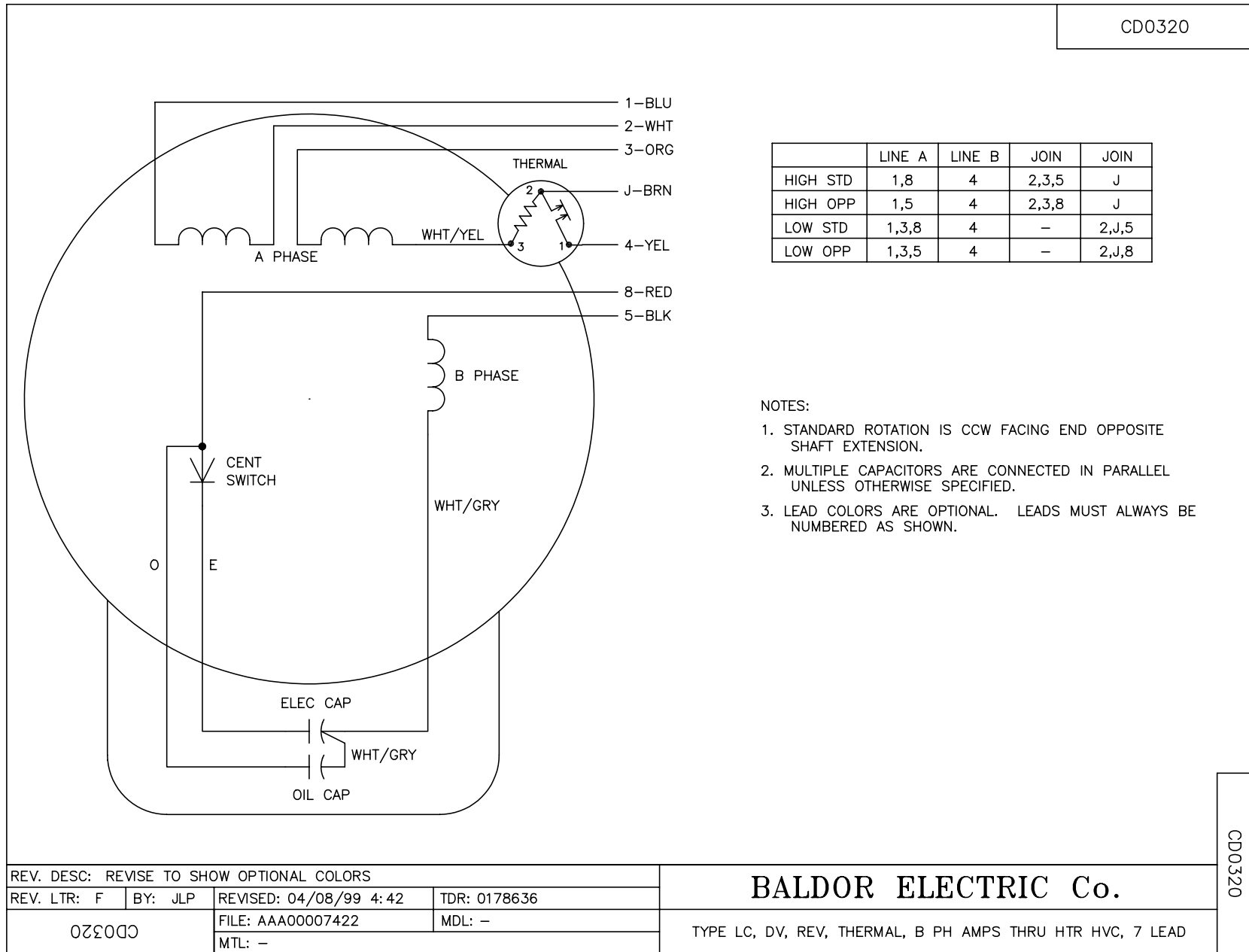

CD0320

REV. DESC: REVISE TO SHOW OPTIONAL COLORS			
REV. LTR: F	BY: JLP	REVISED: 04/08/99 4:42	TDR: 0178636
CD0320		FILE: AAA00007422	MDL: -
		MTL: -	

BALDOR ELECTRIC Co.

TYPE LC, DV, REV, THERMAL, B PH AMPS THRU HTR HVC, 7 LEAD