

BALDOR® • **RELIANCE**

Product Information Packet

FDL3733TM

7.5HP, 1730RPM, 1PH, 60HZ, 213T, 3740LC, TEFC

Copyright © All product information within this document is subject to Baldor Electric Company copyright © protection, unless otherwise noted.

Part Detail							
Revision:	E	Status:	PRD/A	Change #:		Proprietary:	No
Type:	AC	Prod. Type:	3740LC	Elec. Spec:	37WGT879	CD Diagram:	
Enclosure:	TEFC	Mfg Plant:		Mech. Spec:	37K227	Layout:	
Frame:	213T	Mounting:	F1	Poles:	04	Created Date:	03-07-2007
Base:	RG	Rotation:	R	Insulation:	F	Eff. Date:	03-31-2010
Leads:	2#10 A PH,3#14 B&J	Literature:		Elec. Diagram:		Replaced By:	

Nameplate NP1280L										
CAT.NO.	FDL3733TM									
SPEC.	37K227T879G2									
HP	7.5									
VOLTS	230									
AMP	30									
RPM	1730									
FRAME	213T	HZ				60	PH	1		
SER.F.	1.00	CODE				H	DES	L	CL	F
NEMA-NOM-EFF	84	PF				97				
RATING	40C AMB-CONT									
CC					USABLE AT 208V					
DE	6307	ODE				6206				
ENCL	TEFC	SN								

Parts List		
Part Number	Description	Quantity
SA154512	SA 37K227T879G2	1.000 EA
RA143193	RA 37K227T879G2	1.000 EA
OC3050F09SP	CYL OIL CAP 50MFD/370V	1.000 EA
OC3040F09SP	CYL OIL CAP 40MFD/370V	1.000 EA
TPLED1024SP	THERMAL 1PH 1.5 MAN REF LED945 TDR #5817	1.000 EA
EC1189C06SP	ELEC CAP, 189-227 MFD, 250V, 2.06D X 4.	2.000 EA
EC1161C06SP	ELEC CAP, 161-193 MFD, 250V, 2.06D X 4.	2.000 EA
37FN3002A01SP	EXFN, PLASTIC, 9.00 OD, 1.155 ID	1.000 EA
TP5059	GENERIC THERMAL KIT	1.000 EA
HW3200A01	3/8-16X3/4 I-BLT WELDED F/S	1.000 EA
37EP3101A01SP	FR ENDPLATE,TEFC, 37 L&M, W/GREASER	1.000 EA
HW4500A01	1641B(ALEMITE)400 UNIV, GREASE FITT	1.000 EA
13XT0832A07	8-32X7/16 TYP 23 PAN HD SLT DX	2.000 EA
37GS3015	GASKET, CAPAC BOX	1.000 EA
51XW0832A07	8-32 X .44, TAPTITE II, HEX WSHR SLTD SE	6.000 EA
37CB3804A06	CAPAC BOX/COND BOX MACH	1.000 EA
51XW2520A12	.25-20 X .75, TAPTITE II, HEX WSHR SLTD	4.000 EA
HA6003A47	CAPAC CLAMP	1.000 EA
HA6003A45	CAPAC CLAMP - CLIP (WHITE ZINC PLATED)	2.000 EA
51XB1016A07	10-16 X 7/16 HXWSSLD SERTYB	4.000 EA
HA2001A09	SPACER, .218 ID X .937 LG	2.000 EA
51XN1032A28	10-32 X 1 3/4 HX WS SL SR	2.000 EA
HW1000A10	#10 FLAT WASHER (SAE)	2.000 EA
RM1015	BOOT FOR MANUAL THERMALS	1.000 EA

Parts List (continued)		
Part Number	Description	Quantity
XY1032A02	10-32 HEX NUT DIRECTIONAL SERRATION	2.000 EA
HW5100A06	W2420-025 WVY WSHR (WB)	1.000 EA
37EP3100A01SP	STD PU ENDPLATE, ENCL,37 "T"-307 BRG, W/	1.000 EA
HW4500A01	1641B(ALEMITE)400 UNIV, GREASE FITT	1.000 EA
XY3118A12	5/16-18 HEX NUT DIRECTIONAL SERRATION	4.000 EA
51XB1214A20	12-14X1.25 HXWSSLD SERTYB	1.000 EA
07FH4007A06	IEC FH W/GRS, NOT @6, 3 F/C HOL & NOT FO	1.000 EA
51XW1032A06	10-32 X .38, TAPTITE II, HEX WSHR SLTD S	3.000 EA
37CB4509	CAPAC BOX LID, STAMPED	1.000 EA
37GS3016	GASKET, CAPAC BOX LID	1.000 EA
HA1005A07SP	SLINGER, OD 2.25, ID 1.344, 307 BRG	1.000 EA
HW2501F21	KEY, 5/16 SQ X 2.375	1.000 EA
HA7000A02	KEY RETAINER RING, 1 1/8 DIA, 1 3/8 DIA	1.000 EA
85XU0407S04	4X1/4 U DRIVE PIN STAINLESS	2.000 EA
LB1115	LABEL,LIFTING DEVICE	1.000 EA
52XF1032G06	10-32X3/8 HX STD SER TYF	1.000 EA
HW1001A10	WASHER, #10 SPLT LK, ZN X	1.000 EA
MJ1000A75	GREASE, POLYREX EM EXXON	0.050 LB
HA3104A17	5/16-18X13.250 T-BLT/OHIO	4.000 EA
MG1025C02	PAINT, 787.105 LITE TAN EPOXY (USE W/MG1	0.028 GA
MG1025Z20	ACTIVATOR WILKOFAS 060.32	0.010 GA
SP5172A03	37 TYPE L TORQ STAT SWITCH LEAD ASSEMBLY	1.000 EA
NS2539	INSULATOR FOR 37 FRAMESWITCH (MH1011A10)	1.000 EA
WD1000A03	41531 AMP FLG.TERM,4M/REEL(2.5MIL)	12.000 EA

Parts List (continued)		
Part Number	Description	Quantity
LD5000A23	LEAD ASSY, ML1400DF10 W/#10 RING 12"	1.000 EA
LB1119	WARNING LABEL	1.000 EA
LB1087	LABEL,MANUAL RESET (ROLL LABEL)	1.000 EA
LB1172A01	CUSTOM MTR CARTON LABEL LASER PRINTER	1.000 EA
LC0002	CONNECTION LABEL	1.000 EA
NP1280L	ALUM FARM DUTY UL CSA CC THERMAL	1.000 EA
G0PA1000	PACKAGING GROUP	1.000 EA

Accessories		
Part Number	Description	Multiplier
37-3301	C FACE KIT	P1

37LYK227

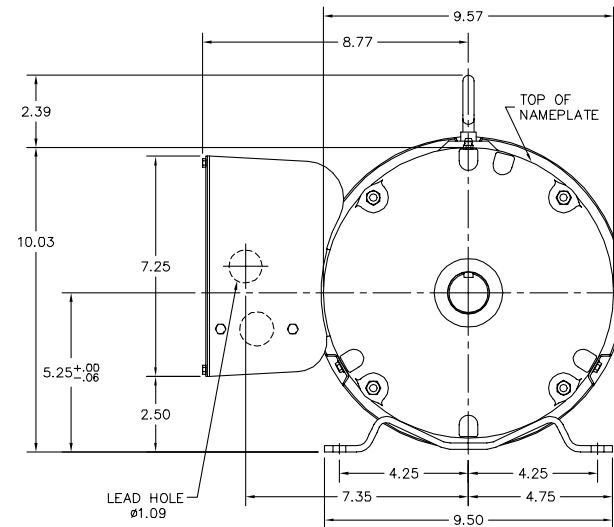
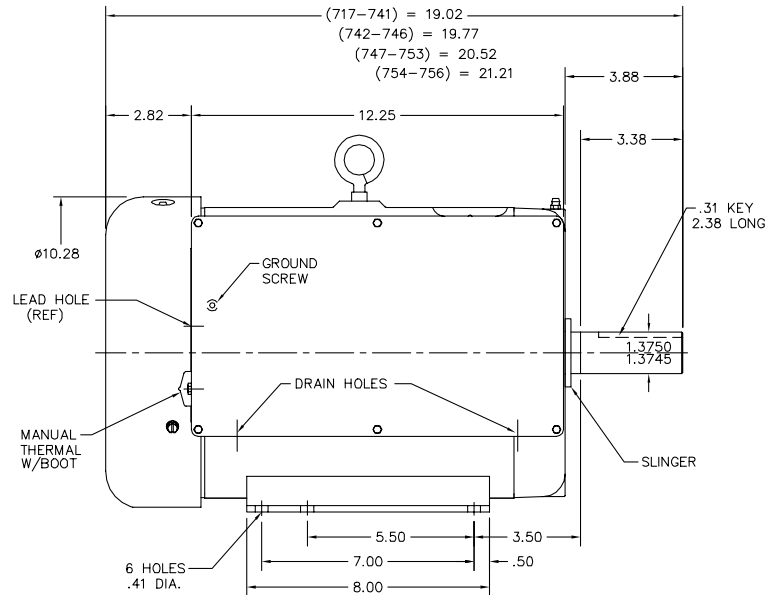

CUSTOMER IS RESPONSIBLE FOR DETERMINING THAT MOTOR PERFORMANCE IS SUITABLE IN THE APPLICATION.

REV. DESC: NEW		
REV. LTR: -	VERSION: 00	TDR: 000000394054
FILE: \AAA\00136\137	REVISED: 11:10:48 04/28/2006	BY: ENJASF0
MTL: -		

BALDOR ELECTRIC Co.	
HORZ NEMA 213-ST TEFC 37LC(FARM DUTY MTR)W/LE MTO,SPL STACKS	

37LYK227

CD0152

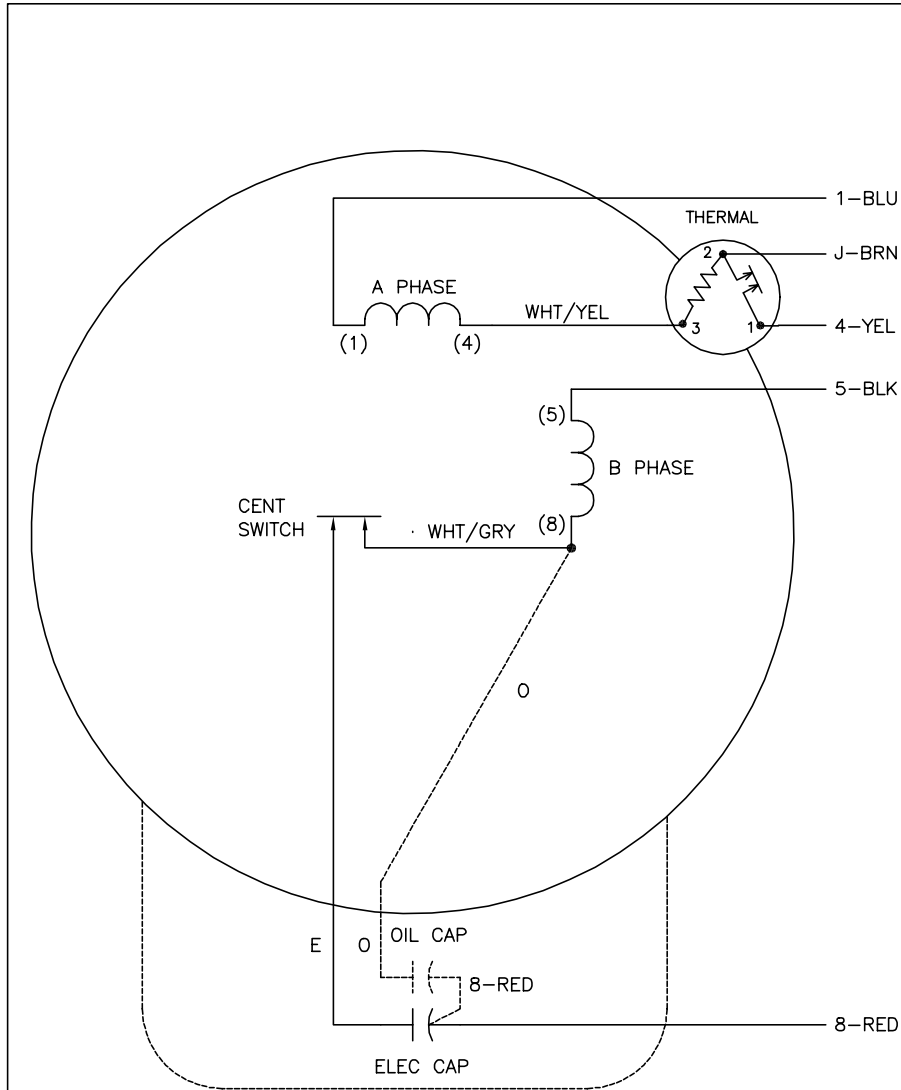

	LINE A	LINE B	JOIN
STD	1,8	4	J,5
OPP	1,5	4	J,8

NOTES:

1. STANDARD ROTATION IS CCW FACING END OPPOSITE SHAFT EXTENSION.
2. MULTIPLE CAPACITORS ARE CONNECTED IN PARALLEL UNLESS OTHERWISE SPECIFIED.
3. OPTIONAL OIL CAPACITOR IS PROVIDED WHEN SPECIFIED.
4. CAPACITORS MAY BE SEPERATELY MOUNTED.
5. LEAD COLORS ARE OPTIONAL. LEADS MUST ALWAYS BE NUMBERED AS SHOWN.

REV. DESC: REMOVE OPTIONAL THERMAL CONNECTION		
REV. LTR: D	VERSION: 01	TDR: 000000373039
ZS1000	FILE: \AAA\00026\903	REVISED: 11:23:45 08/11/2005
	MTL: -	BY: ENJOEPO

BALDOR ELECTRIC Co.

TYPE L OR LC, SV, REV, 5 LDS, THERM, CAPS MAY BE SEP MTD

CD0152