

BALDOR® • *RELIANCE*

Product Information Packet

IDCSWDM3558

2HP,1750RPM,3PH,60HZ,56C,3528M,TEFC,F1,N

Copyright © All product information within this document is subject to Baldor Electric Company copyright © protection, unless otherwise noted.

Part Detail							
Revision:	K	Status:	PRD/A	Change #:		Proprietary:	No
Type:	AC	Prod. Type:	3528M	Elec. Spec:	35WGP562	CD Diagram:	
Enclosure:	TEFC	Mfg Plant:		Mech. Spec:	35S641	Layout:	
Frame:	56C	Mounting:	F1	Poles:	04	Created Date:	08-12-2010
Base:	RG	Rotation:	R	Insulation:	H	Eff. Date:	10-17-2012
Leads:	9#18	Literature:		Elec. Diagram:		Replaced By:	

Nameplate NP1608L

CAT NO	IDCSWDM3558						
SPEC.	35S641P562G1						
FRAME	56C	HP	2	TE			
VOLTS	230/460						
MAG CUR	3.4/1.7	FLA	5.8/2.9				
RPM	1750	RPM MAX	4500				
HZ	60	PH	3	CLASS	H		
SER.F.	1.00	DES	B	SL HZ	1.7		
NEMA-NOM-EFF	86.5	WK2	0.165				
BLWR V		PH		HZ		A	
RATING	40C AMB-CONT						
DE BRG	6205	ODE BRG	6203				
CC		SN					

Parts List		
Part Number	Description	Quantity
SA201610	SA 35S641P562G1	1.000 EA
RA188905	RA 35S641P562G1	1.000 EA
NS2512A01	INSULATOR, CONDUIT BOX X	1.000 EA
35CB5001A03	CONDUIT BOX KIT, FOR SUPER II WASHDOWN	1.000 EA
11XW1032G06	10-32 X .38, TAPTITE II, HEX WSHR SLTD U	1.000 EA
HW3001B01	003SS CUP WASHER, FOR #8 SCREW	1.000 EA
35EP3100M08MU	FREP TEFC 203 BRG NO GRSR, BALL BURNISH	1.000 EA
HW4500A33	1/8 NPT STAINLESS,HOLO-KROME #13002,PRES	3.000 EA
HW5100A03SP	WAVY WASHER (W1543-017)	1.000 EA
35EP3300A75MU	PU E.P., CAST-FACE MTD-56C-205 BRG(BALL	1.000 EA
HW4500A33	1/8 NPT STAINLESS,HOLO-KROME #13002,PRES	3.000 EA
HW4606A02	JM CLIPPER/SEAL (LWE-0938-1624-AL23)	1.000 EA
12XN1032S20	10-32 X 1-1/4 HEX M.S. , STAINLESS STEEL	2.000 EA
HA1049A01	DUBO LOK WASHER SIZE 10 (NYLON LOCK SEAL	4.000 EA
HA1049A01	DUBO LOK WASHER SIZE 10 (NYLON LOCK SEAL	2.000 EA
51XB1214A16	12-14X1.00 HXWSSLD SERTYB	1.000 EA
35FH4005A53	IEC FH NO GREASER (CLEAN ONLY)	1.000 EA
11XW1032S06	10-32 X .38, TAPTITE II, HEX WSHR SLTD U	3.000 EA
HA1005A05SP	SLINGER, OD 1.50, ID .659, 203 BRG	1.000 EA
HW2502D13	SS KEY, 3/16 SQ X 1.375	1.000 EA
HA7000A04	KEY RETAINER 0.625 DIA SHAFTS	1.000 EA
MJ5001A02	732 CL SEALANT 3 OZ DIXIE BEARING 289100	0.001 EA
85XU0407S04	4X1/4 U DRIVE PIN STAINLESS	2.000 EA
LB1164	LABEL,WARNING AND DRAIN	1.000 EA

Parts List (continued)		
Part Number	Description	Quantity
HA5027A04	HA4054 T-DRAIN X2 BAGGED	1.000 EA
MJ1000A75	GREASE, POLYREX EM EXXON	0.050 LB
35FN3002A05SP	EXFN, PLASTIC, 6.376 OD, .638 ID	1.000 EA
HA3100S24	THRUBOLT 8.625 LENGTH 1.250 TH LENGTH SS	4.000 EA
LB1125C01	STD (STOCK) CARTON LABEL BALDOR WITH FLA	1.000 EA
LC0145B01	CONNECTION LABEL	1.000 EA
NP1608L	SS WD INV UL CSA CC REV MTG	1.000 EA
PA1000	PACKING GROUP 3500 SHORT	1.000 EA

Performance Data at 460V, 60Hz, 2.0HP (Typical performance - Not guaranteed values)

General Characteristics							
Full Load Torque:	6.01 LB-FT			Start Configuration:	DOL		
No-Load Current:	1.72 Amps			Break-Down Torque:	24.6 LB-FT		
Line-line Res. @ 25°C.:	7.66 Ohms A Ph / 0.0 Ohms B Ph			Pull-Up Torque:	12.2 LB-FT		
Temp. Rise @ Rated Load:	75 C			Locked-Rotor Torque:	17.9 LB-FT		
Temp. Rise @ S.F. Load:	90 C			Starting Current:	23.7 Amps		
Load Characteristics							
% of Rated Load	25	50	75	100	125	150	S.F.
Power Factor:	33.0	53.0	67.0	75.0	80.0	84.0	0.0
Efficiency:	77.7	85.4	86.9	86.6	85.8	84.2	0.0
Speed:	1789.0	1778.0	1765.0	1751.0	1737.0	1721.0	0.0
Line Amperes:	1.8	2.04	2.39	2.88	3.39	4.01	0.0

Performance Graph at 460V, 60Hz, 2.0HP Typical performance - Not guaranteed values

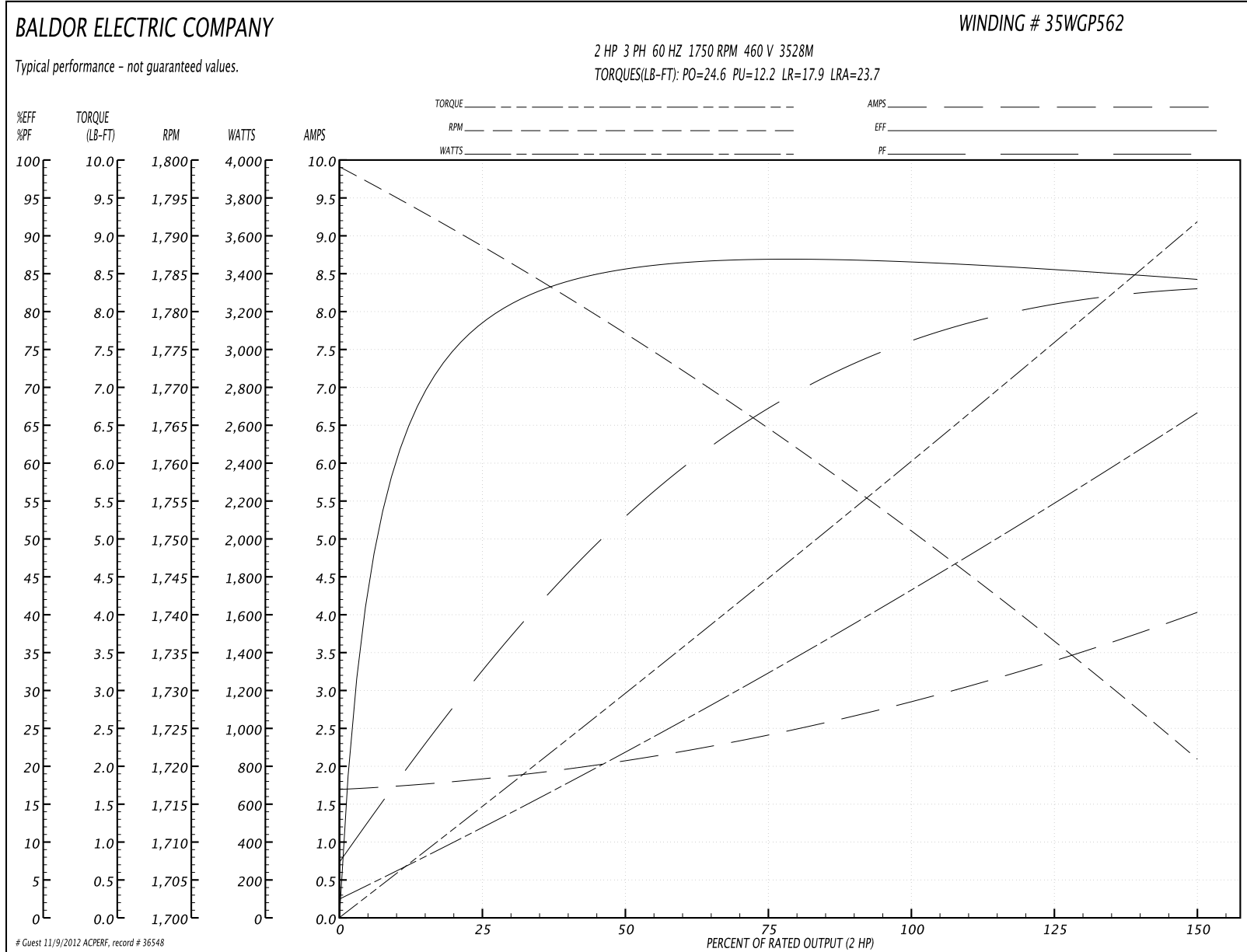

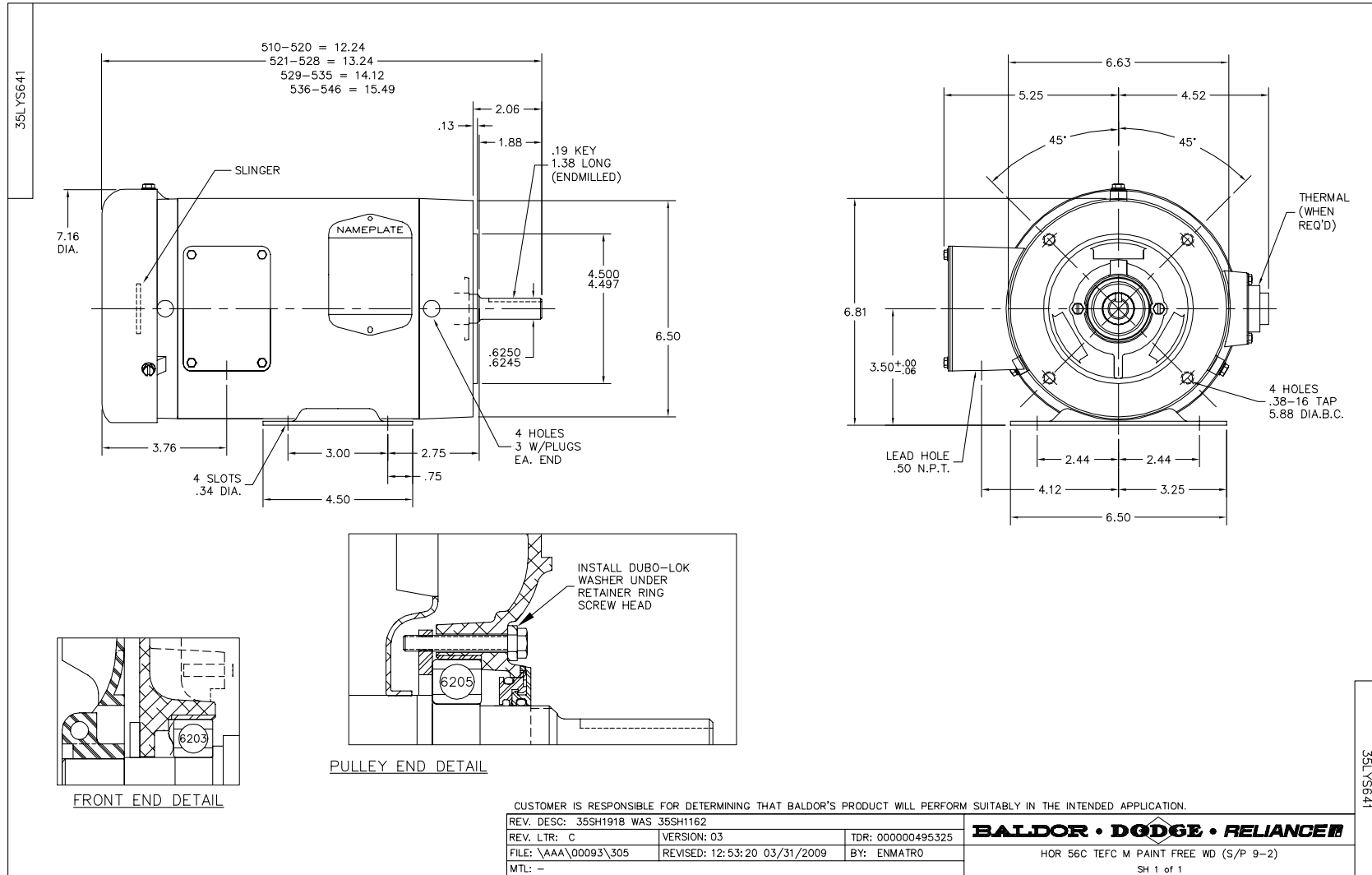

CD0005

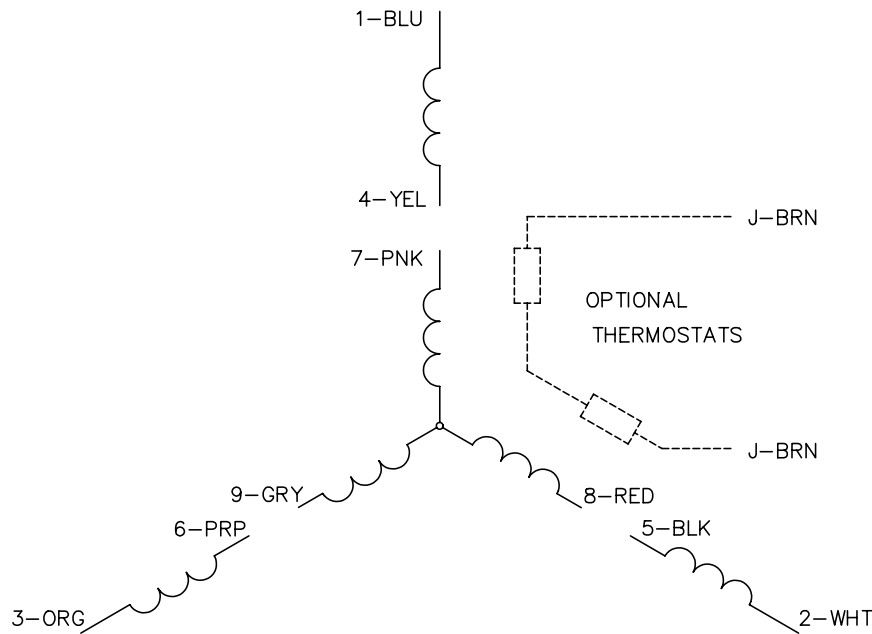

LOW VOLTAGE
(2Y)



LINE

HIGH VOLTAGE
(1Y)

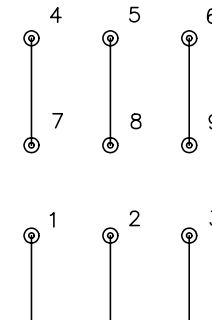

LINE

NOTES:

1. INTERCHANGE ANY TWO LINE LEADS TO REVERSE ROTATION.
2. OPTIONAL THERMOSTATS ARE PROVIDED WHEN SPECIFIED.
3. ACTUAL NUMBER OF INTERNAL PARALLEL CIRCUITS MAY BE A MULTIPLE OF THOSE SHOWN ABOVE.
4. LEAD COLORS ARE OPTIONAL. LEADS MUST ALWAYS BE NUMBERED AS SHOWN.

REV. DESC: REVISE TO SHOW OPTIONAL COLORS			
REV. LTR: E	BY: JLP	REVISED: 01/19/99 10:15	TDR: 0171435
90000		FILE: AAA00005140	MDL: -
		MTL: -	

BALDOR ELECTRIC Co.

3PH, DV, 9 LEADS

CD0005