

BALDOR® • RELIANCE

Product Information Packet

JML1508T

5HP,1745RPM,1PH,60HZ,213JM,3727L,OPSB,F1

Copyright © All product information within this document is subject to Baldor Electric Company copyright © protection, unless otherwise noted.

Part Detail							
Revision:	G	Status:	PRD/A	Change #:		Proprietary:	No
Type:	AC	Prod. Type:	3727L	Elec. Spec:	37WGT912	CD Diagram:	
Enclosure:	OPSB	Mfg Plant:		Mech. Spec:	37K238	Layout:	
Frame:	213JM	Mounting:	F1	Poles:	04	Created Date:	06-22-2006
Base:	RG	Rotation:	R	Insulation:	B	Eff. Date:	01-07-2010
Leads:	2#10 A PH,2#14 B PH	Literature:		Elec. Diagram:		Replaced By:	

Nameplate NP1256L									
CAT.NO.	JML1508T								
SPEC.	37K238T912								
HP	5								
VOLTS	230								
AMP	27								
RPM	1725								
FRAME	213JM	HZ	60	PH	1				
SER.F.	1.15	CODE	G	DES	L	CLASS	B		
NEMA-NOM-EFF	77	PF	78						
RATING	40C AMB-CONT								
CC	USABLE AT 208V								
DE	6309	ODE	6206						
ENCL	OPSB	SN							

Parts List		
Part Number	Description	Quantity
SA144483	SA 37K238T912	1.000 EA
RA133672	RA 37K238T912	1.000 EA
EC1216C06SP	ELEC CAP, 216-259 MFD, 250V, 2.06D X 4.	2.000 EA
37CB3006	37 CB CASTING W/1.38 LEAD HOLE @ 6:00	1.000 EA
51XW2520A10	.25-20 X .62, TAPTITE II, HEX WSHR SLTD	2.000 EA
11XW1032G06	10-32 X .38, TAPTITE II, HEX WSHR SLTD U	1.000 EA
37EP3200A32	FR 37L&M OPEN RODENT SCREEN W/GRS & RELI	1.000 EA
HW4500A01	1641B(ALEMITE)400 UNIV, GREASE FITT	1.000 EA
HW4500A17	317400 ALEMITE GREASE RELIEF	1.000 EA
HA1104A01	RODENT SCREEN 37 FRAME 206 BRG FRONT END	1.000 EA
51XW1032A06	10-32 X .38, TAPTITE II, HEX WSHR SLTD S	4.000 EA
HW1000A10	#10 FLAT WASHER (SAE)	4.000 EA
37AD2005	BAFFLE PLATE, FOR OPSB 1 PHASE	1.000 EA
SP1008A01	BAFFLE, MODEL 36 & 37	1.000 EA
13XT0832A07	8-32X7/16 TYP 23 PAN HD SLT DX	2.000 EA
10XN2520A10	1/4-20X 5/8 HEX HD X	2.000 EA
HW1001A25	LOCKWASHER 1/4, ZINC PLT .493 OD, .255 I	2.000 EA
HW5100A06	W2420-025 WVY WSHR (WB)	1.000 EA
37EP3401A12	PUEP W/GRS, REL, SLINGER MF, NO BAFFLE	1.000 EA
HW4500A01	1641B(ALEMITE)400 UNIV, GREASE FITT	1.000 EA
HW4500A17	317400 ALEMITE GREASE RELIEF	1.000 EA
HA1222	RODENT SCREEN - 37 C-FACE MOTORS	1.000 EA
51XW1032A06	10-32 X .38, TAPTITE II, HEX WSHR SLTD S	4.000 EA
HW1000A10	#10 FLAT WASHER (SAE)	4.000 EA

Parts List (continued)		
Part Number	Description	Quantity
10XN2520A36	1/4-20X 2 1/4 HEX HD X	4.000 EA
HW1001A25	LOCKWASHER 1/4, ZINC PLT .493 OD, .255 I	4.000 EA
XY3118A12	5/16-18 HEX NUT DIRECTIONAL SERRATION	4.000 EA
37CB4516	LIPPED LID FOR 37 FRAME NEC KOBX	1.000 EA
51XW0832A07	8-32 X .44, TAPTITE II, HEX WSHR SLTD SE	4.000 EA
HW4600A73	SEAL 1.748 X 2.375 X 0.250 FACE SEALING	1.000 EA
HW2501D13SP	KEY, 3/16 SQ X 1.375	1.000 EA
HA7000A01	KEY RETAINER 7/8" DIA SHAFT	1.000 EA
85XU0407S04	4X1/4 U DRIVE PIN STAINLESS	2.000 EA
37CB3802SP	CAPACITOR COVER, CAST	1.000 EA
MJ1000A75	GREASE, POLYREX EM EXXON	0.050 LB
SP5061A13	MODEL 37 TYPE L STAT SWITCH LEAD ASSEMBL	1.000 EA
WD1000A15	3-520132-2 AMP FLAG (4M/RL NON-CANC/NON-	4.000 EA
HA6003A38	CLAMP, CAPACITOR	1.000 EA
51XW0832A07	8-32 X .44, TAPTITE II, HEX WSHR SLTD SE	2.000 EA
37AD2001A01	BAFFLE PLATE, STAMPED	1.000 EA
HA3104A14	THRUBOLT- 5/16-18 X12.125(OHIO)	4.000 EA
MG1000G27	PAINT- S9282E CHARCOAL GREY	0.028 GA
LB1119	WARNING LABEL	1.000 EA
LB1125C01	STD (STOCK) CARTON LABEL BALDOR WITH FLA	1.000 EA
LC0017	CONN LABEL-1 PHASE-SINGLE VOLT-REV ROTNO	1.000 EA
NP1256L	ALUM UL CSA CC	1.000 EA
GOPA1000	PACKAGING GROUP	1.000 EA

Performance Data at 230V, 60Hz, 5.0HP (Typical performance - Not guaranteed values)

General Characteristics							
Full Load Torque:	15.3 LB-FT			Start Configuration:	DOL		
No-Load Current:	14.3 Amps			Break-Down Torque:	43.0 LB-FT		
Line-line Res. @ 25°C.:	0.352 Ohms A Ph / 1.48 Ohms B Ph			Pull-Up Torque:	30.8 LB-FT		
Temp. Rise @ Rated Load:	68 C			Locked-Rotor Torque:	46.9 LB-FT		
Temp. Rise @ S.F. Load:	81 C			Starting Current:	132.0 Amps		
Load Characteristics							
% of Rated Load	25	50	75	100	125	150	S.F.
Power Factor:	38.0	58.0	72.0	78.0	81.0	82.0	80.0
Efficiency:	71.2	79.4	78.0	77.3	74.0	67.1	75.3
Speed:	1781.0	1766.0	1749.0	1728.0	1699.0	1653.0	1711.0
Line Amperes:	14.9	17.5	21.9	27.1	33.9	44.4	31.2

Performance Graph at 230V, 60Hz, 5.0HP Typical performance - Not guaranteed values

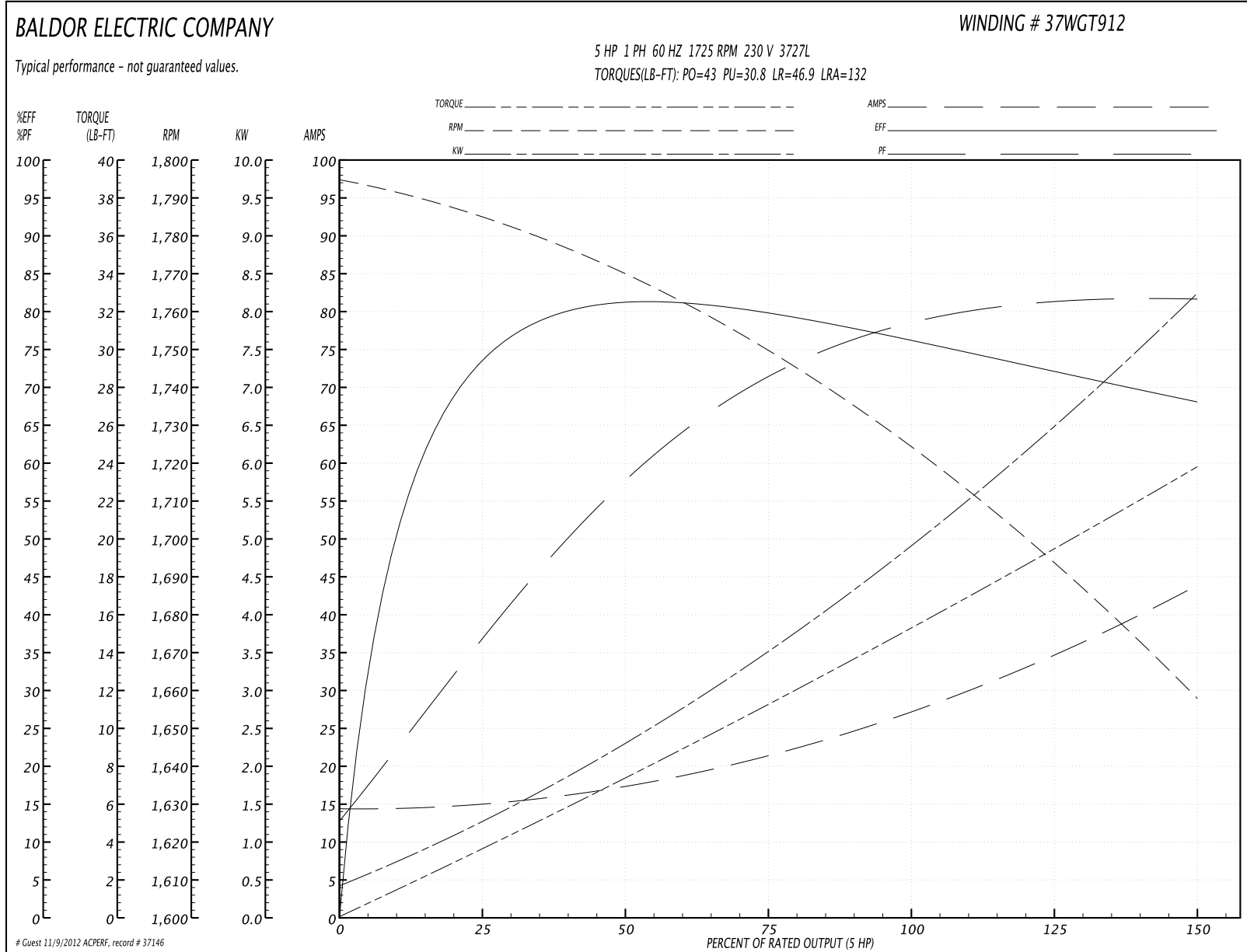

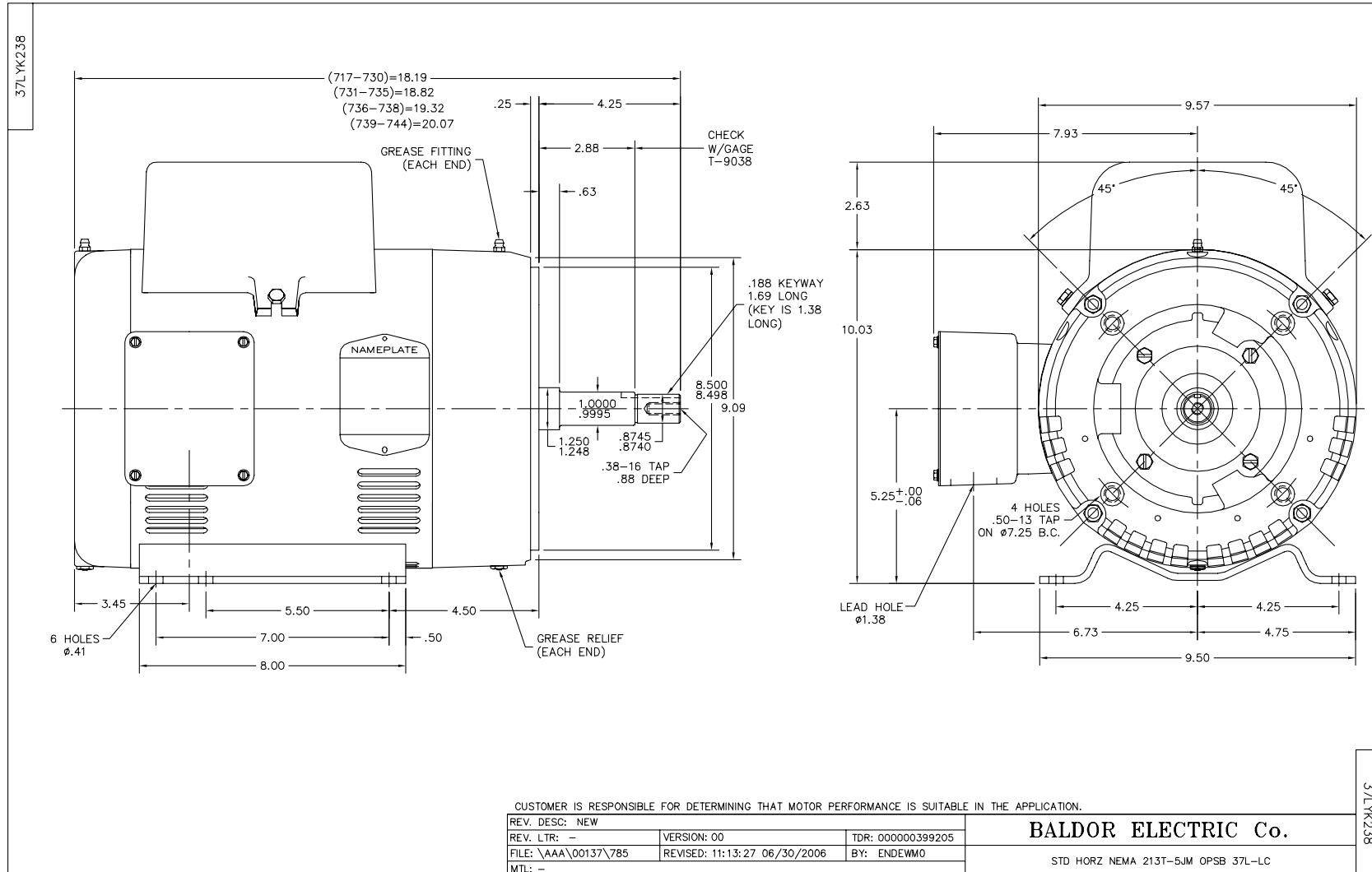

CD0017A01

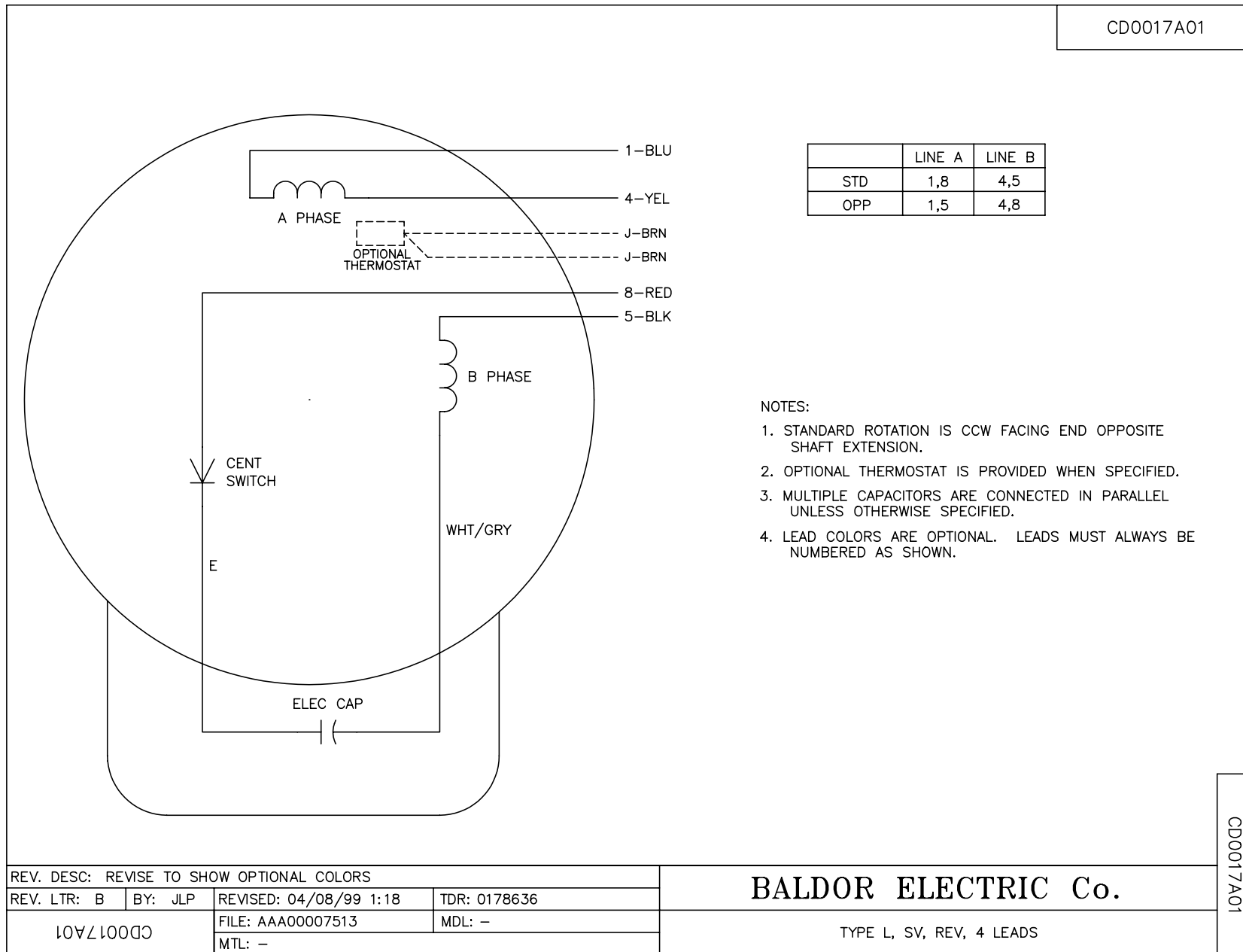

REV. DESC: REVISE TO SHOW OPTIONAL COLORS			
REV. LTR: B	BY: JLP	REVISED: 04/08/99 1:18	TDR: 0178636
CD0017A01		FILE: AAA00007513	MDL: -
		MTL: -	

BALDOR ELECTRIC Co.

TYPE L, SV, REV, 4 LEADS

CD0017A01