

# **BALDOR® • RELIANCE**

## **Product Information Packet**

### **M1557T**

**3/.75HP, 1725/850RPM, 3PH, 60HZ, 184T, 3628M**

Copyright © All product information within this document is subject to Baldor Electric Company copyright © protection, unless otherwise noted.

Part Detail							
Revision:	T	Status:	PRD/A	Change #:		Proprietary:	No
Type:	AC	Prod. Type:	3628M	Elec. Spec:	36WGX365	CD Diagram:	
Enclosure:	TEFC	Mfg Plant:		Mech. Spec:	36A001	Layout:	
Frame:	184T	Mounting:	F1	Poles:	04/08	Created Date:	
Base:	RG	Rotation:	R	Insulation:	F	Eff. Date:	05-06-2009
Leads:	6#16	Literature:		Elec. Diagram:		Replaced By:	

Nameplate NP1256L									
CAT.NO.	M1557T								
SPEC.	36A01X365								
HP	3/.75								
VOLTS	208-230								
AMP	8/3								
RPM	1725/850								
FRAME	184T	HZ	60	PH	3				
SER.F.	1.15	CODE	G	DES	B	CLASS	F		
NEMA-NOM-EFF		PF							
RATING	40C AMB-CONT								
CC		USABLE AT 208V							
DE	6206	ODE	6205						
ENCL	TEFC	SN							

Parts List		
Part Number	Description	Quantity
SA033915	SA 36A01X365	1.000 EA
RA029943	RA 36A01X365	1.000 EA
36CB3004	36 CB CASTING W/1.09 DIA LEAD HOLE @ 6:0	1.000 EA
36GS1000SP	GASKET-CONDUIT BOX, .06 THICK #SV-330 LE	1.000 EA
51XB1016A08	10-16X 1/2HXWSSLD SERTYB	2.000 EA
11XW1032G06	10-32 X .38, TAPTITE II, HEX WSHR SLTD U	1.000 EA
HW3001B01	003SS CUP WASHER, FOR #8 SCREW	1.000 EA
36EP3104A01	FREP MACH W/GRSR, RAISED FH PADS	1.000 EA
HW4500A01	1641B(ALEMITE)400 UNIV, GREASE FITT	1.000 EA
HW5100A05	WVY WSHR F/205 & 304 BRGS	1.000 EA
36EP3100A01SP	PU ENDPLATE, MACH	1.000 EA
HW4500A01	1641B(ALEMITE)400 UNIV, GREASE FITT	1.000 EA
XY2520A12	1/4-20 HEX NUT, DIRECTIONAL SERRATIONS	4.000 EA
51XB1214A16	12-14X1.00 HXWSSLD SERTYB	1.000 EA
36FH4009A102SP	IEC FH GREASER W/AUTOPHERETIC PRIMER	1.000 EA
51XW1032A06	10-32 X .38, TAPTITE II, HEX WSHR SLTD S	3.000 EA
36CB4516	36 LIPPED CB LID	1.000 EA
37GS1001SP	GASKET, CONDUIT BOX LID, .06 THICK LEXID	1.000 EA
51XW0832A07	8-32 X .44, TAPTITE II, HEX WSHR SLTD SE	4.000 EA
HW2501E16	3KEY, 1/4 SQ X 1.750	1.000 EA
HA7000A02	KEY RETAINER RING, 1 1/8 DIA, 1 3/8 DIA	1.000 EA
85XU0407S04	4X1/4 U DRIVE PIN STAINLESS	2.000 EA
MJ1000A75	GREASE, POLYREX EM EXXON	0.050 LB
36FN3000A01SP	EXFN, PLASTIC, 7.00 OD, .912 ID	1.000 EA

Parts List (continued)		
Part Number	Description	Quantity
MG1000G27	PAINT- S9282E CHARCOAL GREY	0.022 GA
HA3101A25	THRUBOLT 1/4-20 X 11.000 OHIO ROD	4.000 EA
LB1119	WARNING LABEL	1.000 EA
LB1125C01	STD (STOCK) CARTON LABEL BALDOR WITH FLA	1.000 EA
LC0032	CONNECTION LABEL	1.000 EA
NP1256L	ALUM UL CSA CC	1.000 EA
36PA1000	PACK GROUP W/LB5001	1.000 EA

Accessories		
Part Number	Description	Multiplier
36-3301	C FACE KIT	A8
36EP1304A62SP	FLANGE MTD ENDPLATE 182-4TD -ENCL (LESS	A8

**Performance Data at 230V, 60Hz, 3.0HP (Typical performance - Not guaranteed values)**

General Characteristics							
Full Load Torque:	9.3 LB-FT			Start Configuration:	DOL		
No-Load Current:	3.4 Amps			Break-Down Torque:	24.0 LB-FT		
Line-line Res. @ 25°C.:	1.99 Ohms A Ph / 0.0 Ohms B Ph			Pull-Up Torque:	17.0 LB-FT		
Temp. Rise @ Rated Load:	84 C			Locked-Rotor Torque:	19.0 LB-FT		
Temp. Rise @ S.F. Load:	105 C			Starting Current:	48.0 Amps		
Load Characteristics							
% of Rated Load	25	50	75	100	125	150	S.F.
Power Factor:	53.0	75.0	84.0	89.0	89.0	88.0	89.0
Efficiency:	73.6	81.0	82.1	80.9	78.5	75.5	79.5
Speed:	1775.0	1752.0	1725.0	1695.0	1660.0	1617.0	1674.0
Line Amperes:	3.8	4.8	6.2	7.8	9.8	12.2	9.0

Performance Graph at 230V, 60Hz, 3.0HP Typical performance - Not guaranteed values

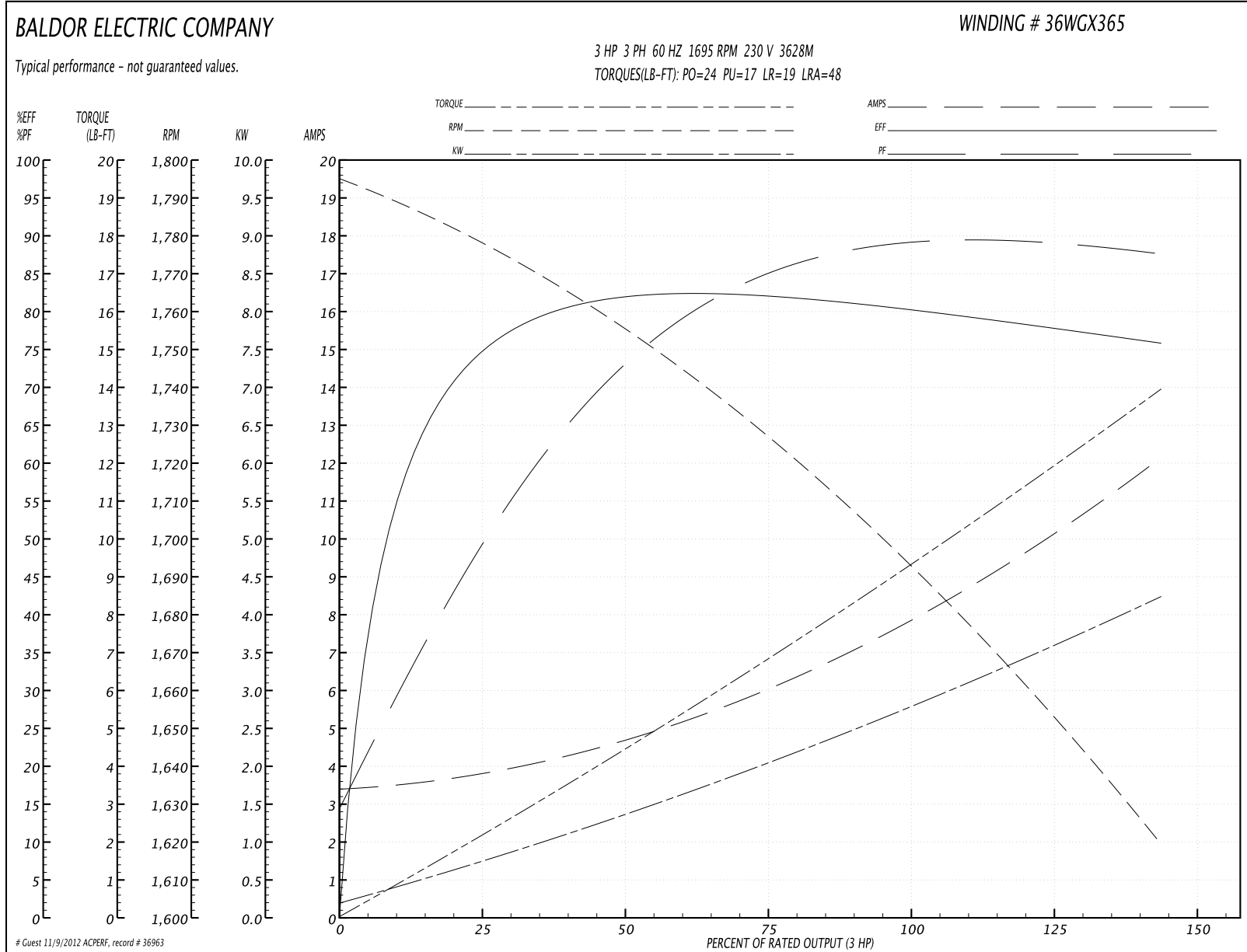

**Performance Data at 230V, 60Hz, 0.75HP (Typical performance - Not guaranteed values)**

General Characteristics			
Full Load Torque:	4.7 LB-FT	Start Configuration:	DOL
No-Load Current:	2.2 Amps	Break-Down Torque:	10.0 LB-FT
Line-line Res. @ 25°C.:	7.95 Ohms A Ph / 0.0 Ohms B Ph	Pull-Up Torque:	7.0 LB-FT
Temp. Rise @ Rated Load:	56 C	Locked-Rotor Torque:	8.1 LB-FT
Temp. Rise @ S.F. Load:	66 C	Starting Current:	10.8 Amps

Load Characteristics							
% of Rated Load	25	50	75	100	125	150	S.F.
Power Factor:	32.0	46.0	59.0	70.0	72.0	75.0	71.0
Efficiency:	52.4	66.0	70.9	71.8	70.7	67.5	71.1
Speed:	887.0	875.0	861.0	845.0	826.0	801.0	834.0
Line Amperes:	2.2	2.4	2.6	2.8	3.4	4.0	3.16



Performance Graph at 230V, 60Hz, 0.75HP Typical performance - Not guaranteed values

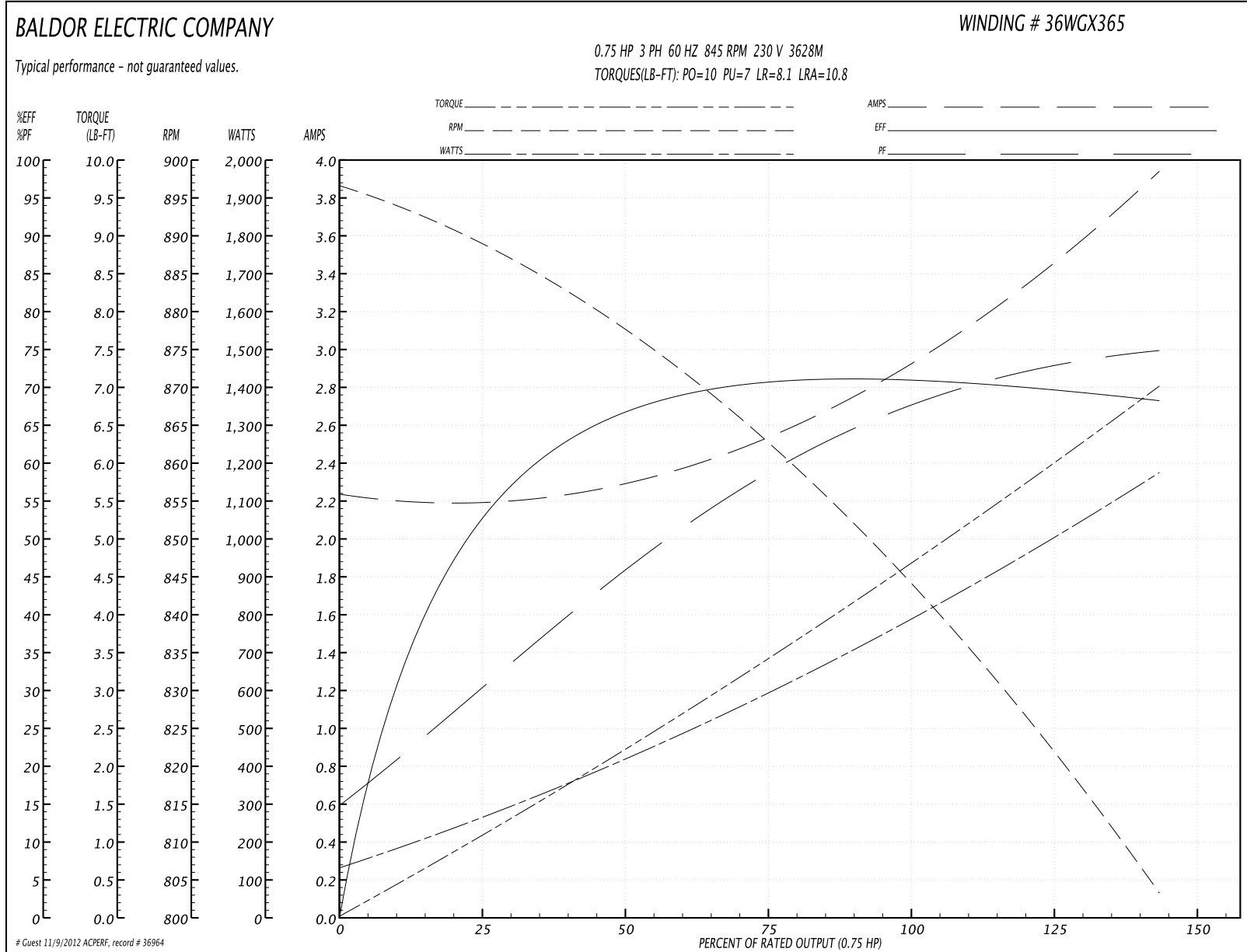

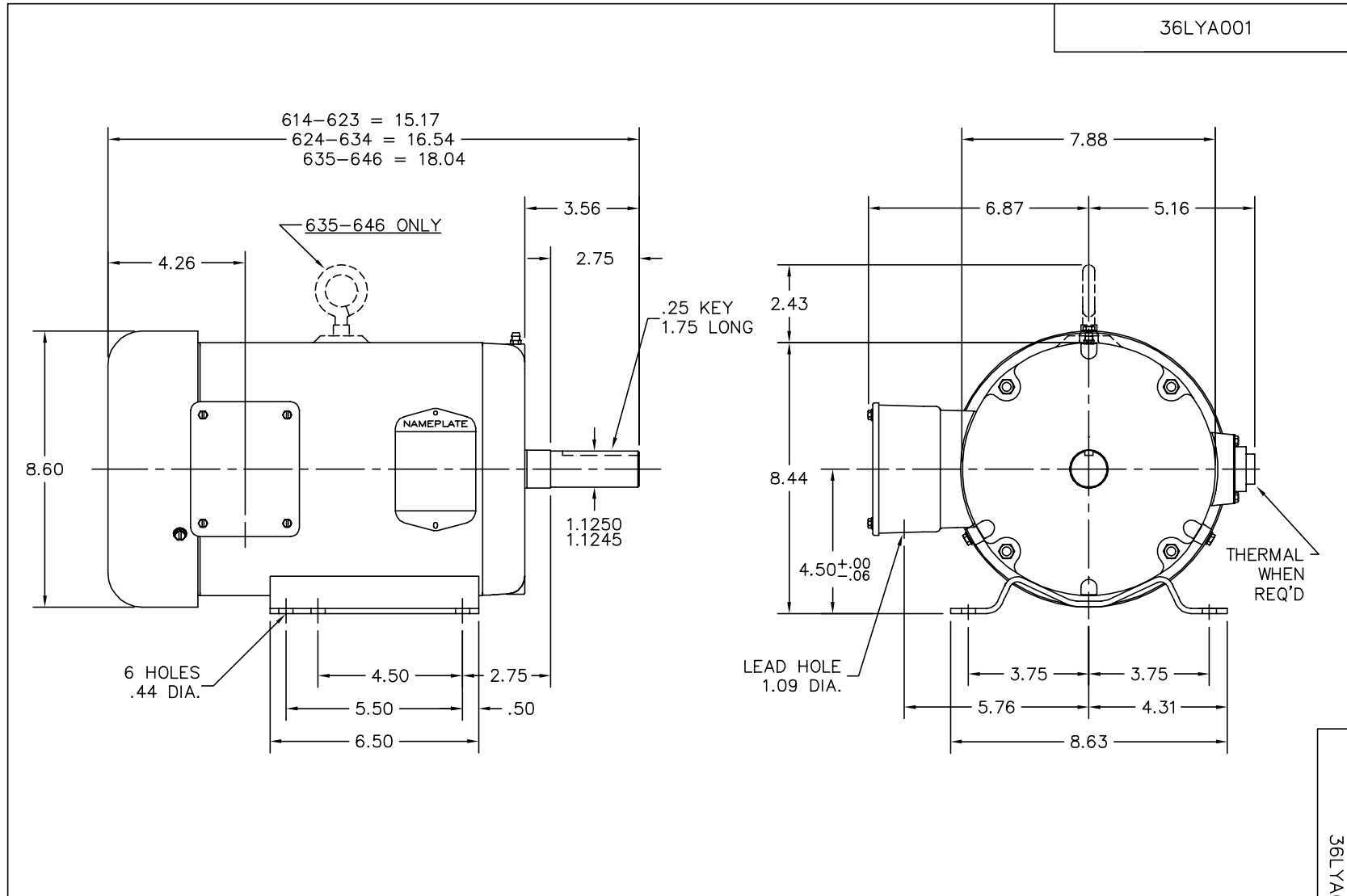

CUSTOMER IS RESPONSIBLE FOR DETERMINING THAT BALDOR'S PRODUCT WILL PERFORM SUITABLY IN THE INTENDED APPLICATION.

REV. DESC: CORRECT DESCRIPTION		
REV. LTR: U	VERSION: 04	TDR: 000000496634
FILE: \AAA\00000\777		REVISED: 15:20:39 04/13/2009
MTL: -		BY: ENBRAMO

**BALDOR • DODGE • RELIANCE**

STD HORZ 182-4T TEFC 36M

SH 1 of 1

36LYA001

CD0032

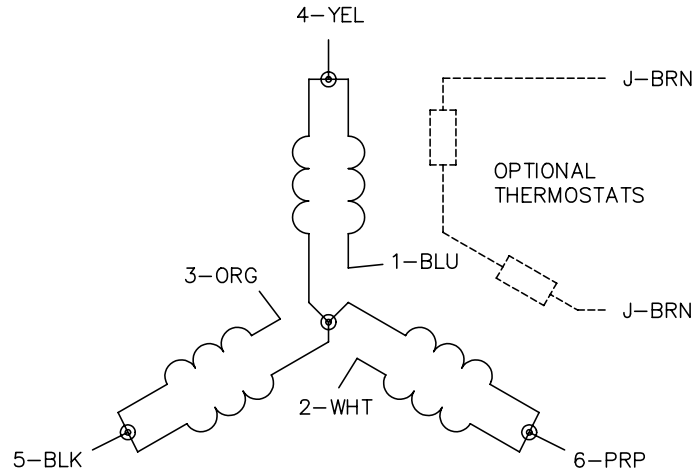

LOW SPEED  
(1Y)

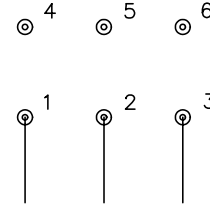

LINE

HIGH SPEED  
(2Y)

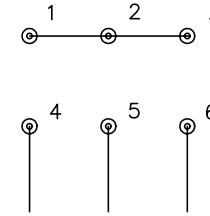

LINE

NOTES:

1. INTERCHANGE ANY TWO LINE LEADS TO REVERSE ROTATION.
2. OPTIONAL THERMOSTATS ARE PROVIDED WHEN SPECIFIED.
3. ACTUAL NUMBER OF INTERNAL PARALLEL CIRCUITS MAY BE A MULTIPLE OF THOSE SHOWN ABOVE.
4. LEAD COLORS ARE OPTIONAL. LEADS MUST ALWAYS BE NUMBERED AS SHOWN.

REV. DESC: REVISE TO SHOW OPTIONAL COLORS			
REV. LTR: E	BY: JLP	REVISED: 01/22/99 8:27	TDR: 0171435
CD0032		FILE: AAA00005145	MDL: -
		MTL: -	

**BALDOR ELECTRIC Co.**

3PH, SV, 6 LEADS, 2-SPEED 1-WINDING VARIABLE TORQUE

CD0032