

BALDOR® • RELIANCE

Product Information Packet

M1762T

20/5HP, 1760/870RPM, 3PH, 60HZ, 284T, 1034M

Copyright © All product information within this document is subject to Baldor Electric Company copyright © protection, unless otherwise noted.

Part Detail							
Revision:	L	Status:	PRD/A	Change #:		Proprietary:	No
Type:	AC	Prod. Type:	1034M	Elec. Spec:	10WGW441	CD Diagram:	
Enclosure:	TEFC	Mfg Plant:		Mech. Spec:	10C151	Layout:	
Frame:	284T	Mounting:	F1	Poles:	04/08	Created Date:	
Base:	RG	Rotation:	R	Insulation:	F	Eff. Date:	11-07-2008
Leads:	6#10	Literature:		Elec. Diagram:		Replaced By:	

Nameplate NP1256L									
CAT.NO.	M1762T								
SPEC.	10C151W441								
HP	20/5								
VOLTS	460								
AMP	26/9.4								
RPM	1760/870								
FRAME	284T	HZ	60	PH	3				
SER.F.	1.15	CODE	F	DES	B	CLASS	F		
NEMA-NOM-EFF		PF							
RATING	40C AMB-CONT								
CC		USABLE AT 208V							
DE	6311	ODE	6309						
ENCL	TEFC	SN							

Parts List		
Part Number	Description	Quantity
SA013447	SA 10C151W441	1.000 EA
RA009644	RA 10C151W441	1.000 EA
10CB3000SP	STD KO BOX MODEL 310,312,314 MTRS W/2.00	1.000 EA
10XN3118K12	5/16-18 X .75 GRADE 5, ZINC PLATED	4.000 EA
HW1001A31	LOCKWASHER 5/16, ZINC PLT.591 OD, .319 I	4.000 EA
WD1000B16	KPA-4C BURNDY TERMINAL	1.000 EA
51XF2520A08	SCREW, HEX SER SLT HD, ZN 1/4-20 X .50 L	1.000 EA
10EP1106A01	FR ENDPLATE, MACH	1.000 EA
10XN3816K32	BOLT, 3/8-16X2 HH YZ(5)	4.000 EA
HW1001A38	LOCKWASHER 3/8, ZINC PLT .688 OD, .382 I	4.000 EA
HW5100A11	W3917-042 WVY WSHR (WB)	1.000 EA
10XN2520K32	1/4-20 X 2.00 HX HD SCRW GRADE 5, ZINC P	2.000 EA
HW1001A25	LOCKWASHER 1/4, ZINC PLT .493 OD, .255 I	2.000 EA
10XN3118K40	5/16-18 X 2.50" HEX HD, GRADE 5	4.000 EA
HW1001A31	LOCKWASHER 5/16, ZINC PLT.591 OD, .319 I	4.000 EA
10EP1105A01	PU ENDPLATE, MACH 284-6T	1.000 EA
10XN3816K28	3/8-16 X 1.75 HEX HD CAP SCREW, GRADE 5	4.000 EA
HW1001A38	LOCKWASHER 3/8, ZINC PLT .688 OD, .382 I	4.000 EA
10FH4000SP	310 FAN HOUSING STAMPED	1.000 EA
10XN2520K08	1/4-20 X .50 GRADE #5, STL, ZINC PLATE	4.000 EA
HW1001A25	LOCKWASHER 1/4, ZINC PLT .493 OD, .255 I	4.000 EA
10CB3500SP	CONDUIT BOX LID, CAST	1.000 EA
51XW2520A12	.25-20 X .75, TAPTITE II, HEX WSHR SLTD	4.000 EA
HW4600B40	V-RING SLINGER 2.000 X 2.680 X 0.280	1.000 EA

Parts List (continued)		
Part Number	Description	Quantity
HW2501H28	KEY, 1/2 SQ X 3.250	1.000 EA
LB1115	LABEL,LIFTING DEVICE	1.000 EA
12GS1000SP	GASKET	1.000 EA
HA4051A00	PLASTIC CAP FOR GREASE FITTING	1.000 EA
HW4500A21	1618BALEMITE FITTING 825 UNIVERSAL	1.000 EA
HA4017A01	1/8 X 4 GREASE EXT (F/S)	1.000 EA
HW4500A17	317400 ALEMITE GREASE RELIEF	1.000 EA
HA4001A01SP	DRAIN PLUG, PLASTIC (MICRO PLAS)	1.000 EA
MJ1000A75	GREASE, POLYREX EM EXXON	0.130 LB
HA4051A00	PLASTIC CAP FOR GREASE FITTING	1.000 EA
HW4500A03	GREASE FITTING, .125 NPT 1610(ALEMITE) 8	1.000 EA
HW4500A17	317400 ALEMITE GREASE RELIEF	1.000 EA
HA4001A01SP	DRAIN PLUG, PLASTIC (MICRO PLAS)	1.000 EA
10GS1000SP	GASKET, CONDUIT BOX LID	1.000 EA
MG1000G27	PAINT- S9282E CHARCOAL GREY	0.070 GA
85XU0407A04	#4-7 X 1/4 DRIVE PIN	2.000 EA
LB5040	INSTRUCTION TAG, AC & DC	1.000 EA
10FN3001A01	EXTERNAL FAN (KENCO)	1.000 EA
HW2500A25	WOODRUFF KEY USA #1008 #BLOW CARBON STEE	1.000 EA
HA6390A01	HOSE CLAMP FOR 3.12 DIA S.S. OR PLATED	1.000 EA
LB1119	WARNING LABEL	1.000 EA
LB1125C01	STD (STOCK) CARTON LABEL BALDOR WITH FLA	4.000 EA
LC0032	CONNECTION LABEL	1.000 EA
NP1256L	ALUM UL CSA CC	1.000 EA

Parts List (continued)		
Part Number	Description	Quantity
10PA1000	PACKAGING GROUP COMBINED PRINT PK1023A06	1.000 EA

Accessories		
Part Number	Description	Multiplier
10-1305	C FACE KIT	A8
10EP1502A01SP	D-FLANGE KIT	A8

Performance Data at 460V, 60Hz, 20.0HP (Typical performance - Not guaranteed values)

General Characteristics							
Full Load Torque:	59.5 LB-FT			Start Configuration:	DOL		
No-Load Current:	9.5 Amps			Break-Down Torque:	129.0 LB-FT		
Line-line Res. @ 25°C.:	0.592 Ohms A Ph / 0.0 Ohms B Ph			Pull-Up Torque:	64.0 LB-FT		
Temp. Rise @ Rated Load:	76 C			Locked-Rotor Torque:	84.0 LB-FT		
Temp. Rise @ S.F. Load:	89 C			Starting Current:	125.0 Amps		
Load Characteristics							
% of Rated Load	25	50	75	100	125	150	S.F.
Power Factor:	54.0	73.0	81.0	85.0	86.0	85.0	86.0
Efficiency:	76.2	84.5	87.0	87.6	87.3	86.4	87.4
Speed:	1792.0	1785.0	1778.0	1770.0	1761.0	1749.0	1765.0
Line Amperes:	11.4	15.1	19.9	25.3	31.3	38.1	28.9

Performance Graph at 460V, 60Hz, 20.0HP Typical performance - Not guaranteed values

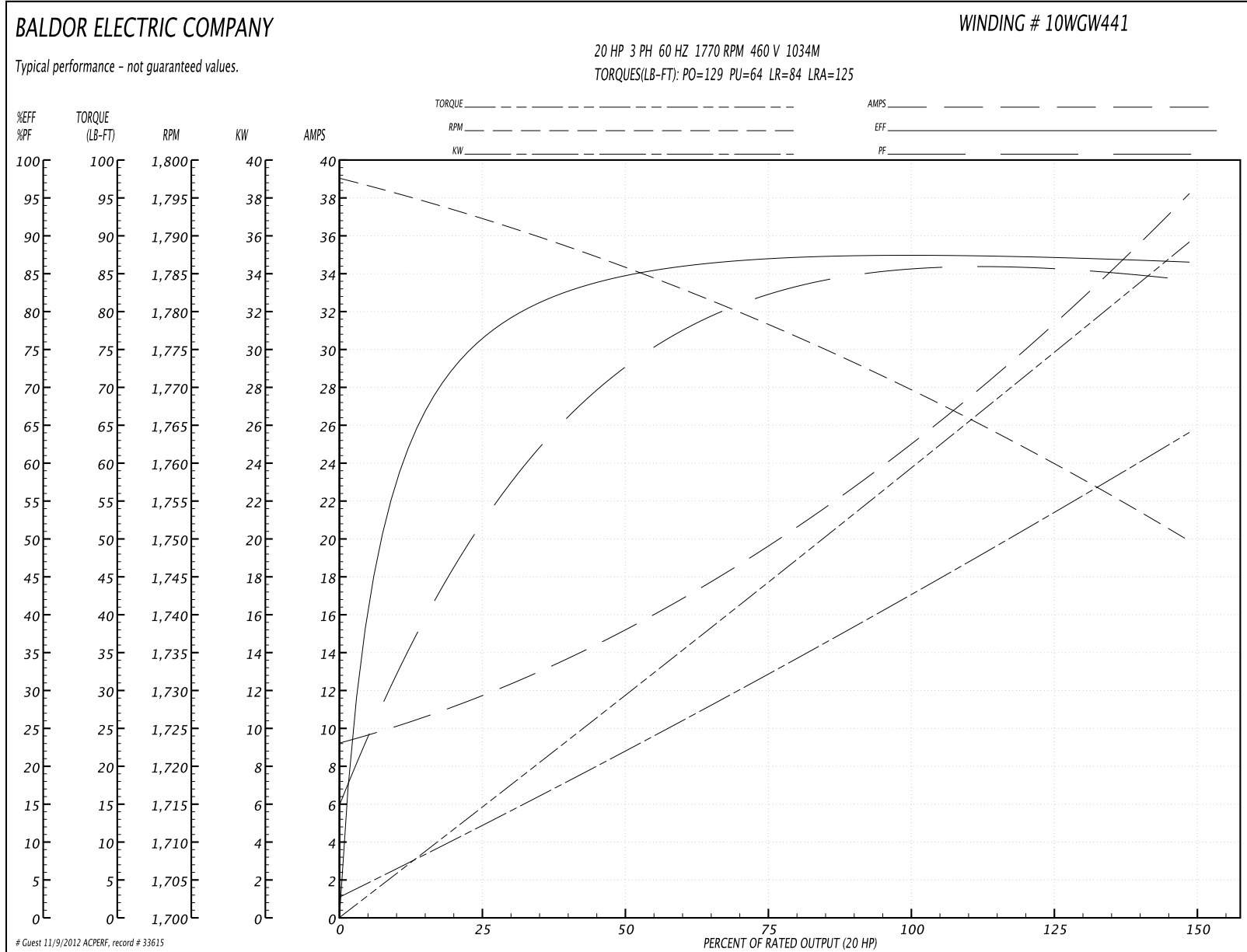

Performance Data at 460V, 60Hz, 5.0HP (Typical performance - Not guaranteed values)

General Characteristics			
Full Load Torque:	29.7 LB-FT	Start Configuration:	DOL
No-Load Current:	6.2 Amps	Break-Down Torque:	54.0 LB-FT
Line-line Res. @ 25°C.:	2.45 Ohms A Ph / 0.0 Ohms B Ph	Pull-Up Torque:	32.0 LB-FT
Temp. Rise @ Rated Load:	39 C	Locked-Rotor Torque:	37.0 LB-FT
Temp. Rise @ S.F. Load:	45 C	Starting Current:	31.0 Amps

Load Characteristics							
% of Rated Load	25	50	75	100	125	150	S.F.
Power Factor:	27.0	43.0	54.0	62.0	67.0	69.0	65.0
Efficiency:	67.3	78.5	82.3	83.6	83.5	82.4	83.5
Speed:	896.0	893.0	889.0	885.0	881.0	874.0	883.0
Line Amperes:	6.4	7.0	7.9	9.1	10.5	12.4	9.94

Performance Graph at 460V, 60Hz, 5.0HP Typical performance - Not guaranteed values

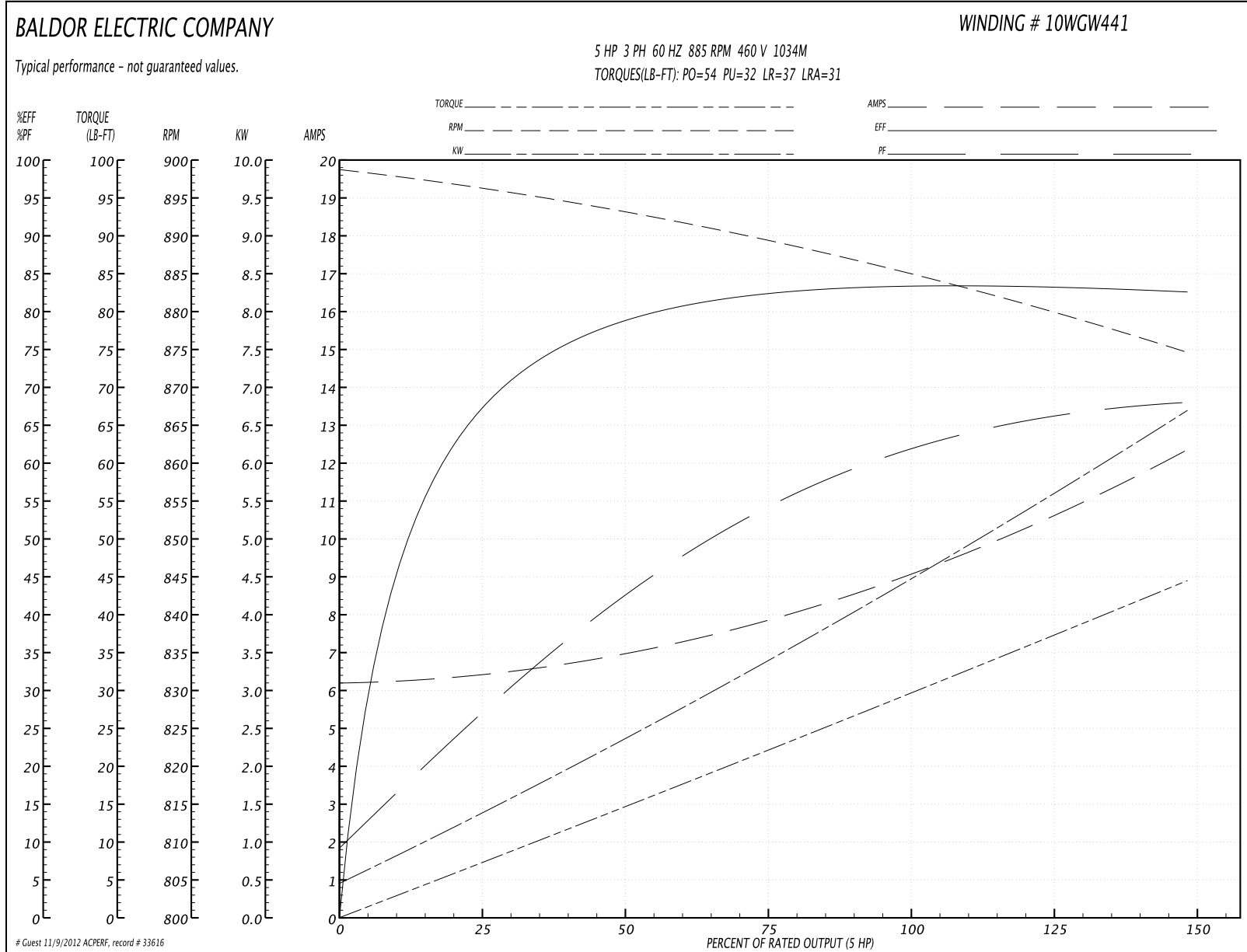

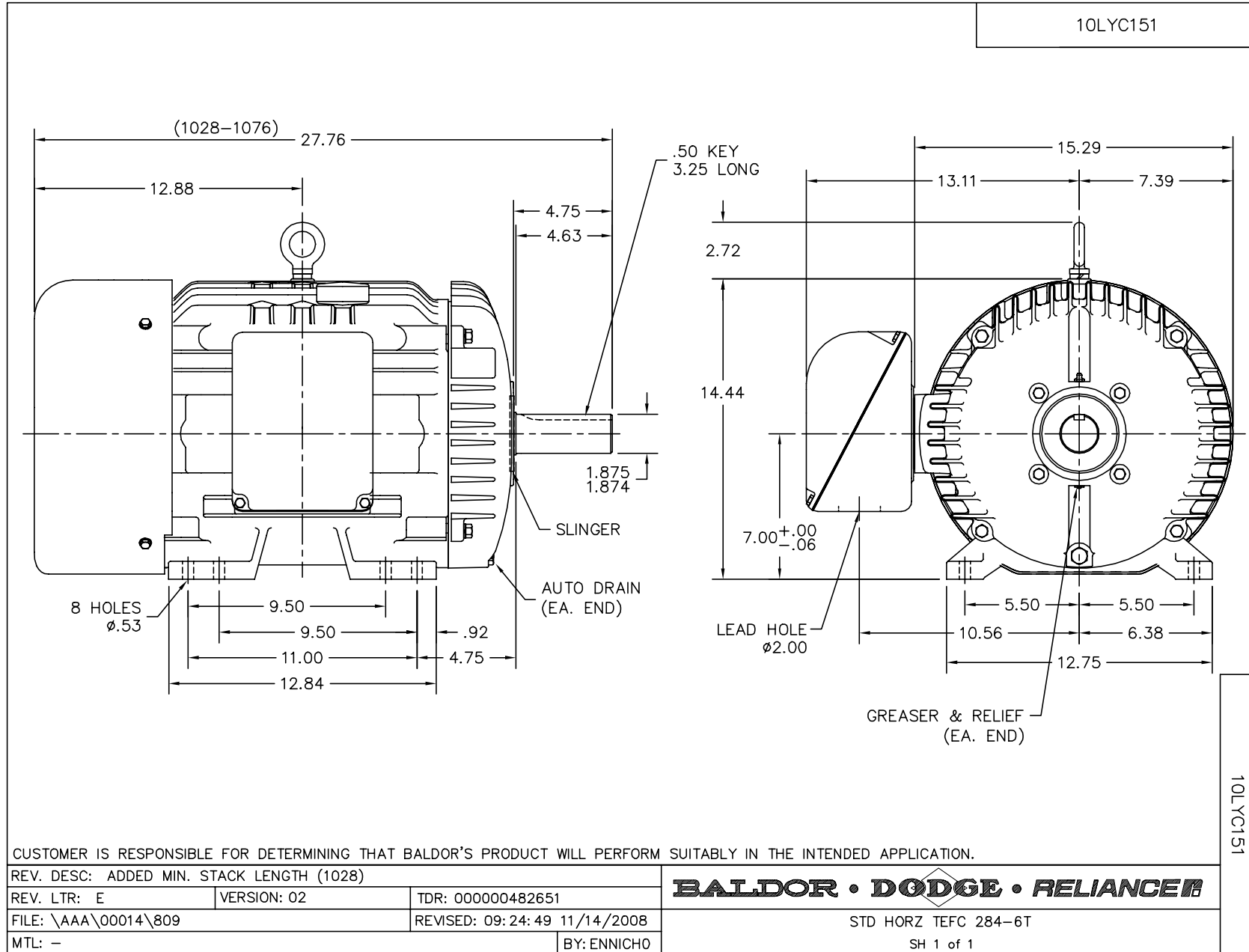

CD0032

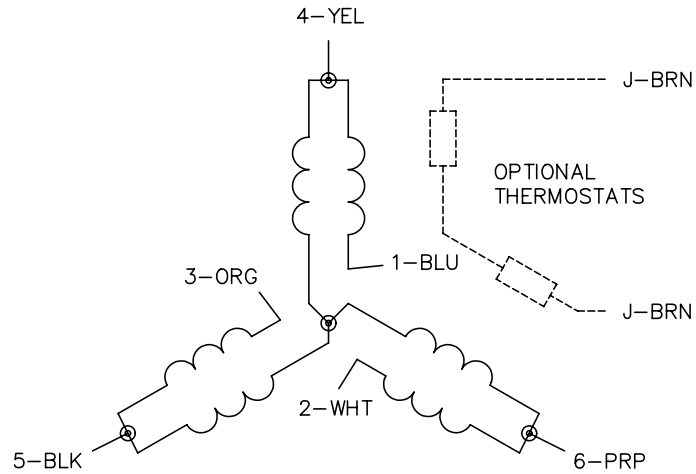

LOW SPEED
(1Y)

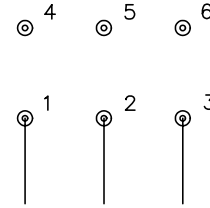

LINE

HIGH SPEED
(2Y)

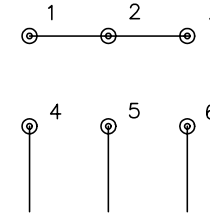

LINE

NOTES:

1. INTERCHANGE ANY TWO LINE LEADS TO REVERSE ROTATION.
2. OPTIONAL THERMOSTATS ARE PROVIDED WHEN SPECIFIED.
3. ACTUAL NUMBER OF INTERNAL PARALLEL CIRCUITS MAY BE A MULTIPLE OF THOSE SHOWN ABOVE.
4. LEAD COLORS ARE OPTIONAL. LEADS MUST ALWAYS BE NUMBERED AS SHOWN.

REV. DESC: REVISE TO SHOW OPTIONAL COLORS			
REV. LTR: E	BY: JLP	REVISED: 01/22/99 8:27	TDR: 0171435
CD0032		FILE: AAA00005145	MDL: -
		MTL: -	

BALDOR ELECTRIC Co.

3PH, SV, 6 LEADS, 2-SPEED 1-WINDING VARIABLE TORQUE

CD0032