

BALDOR® • RELIANCE

Product Information Packet

VECP2276T

7.5HP, 1180RPM, 3PH, 60HZ, 254TC, 0954M, TEFC

Copyright © All product information within this document is subject to Baldor Electric Company copyright © protection, unless otherwise noted.

Part Detail							
Revision:	M	Status:	PRD/A	Change #:		Proprietary:	No
Type:	AC	Prod. Type:	0954M	Elec. Spec:	09WGX827	CD Diagram:	
Enclosure:	TEFC	Mfg Plant:		Mech. Spec:	09H181	Layout:	
Frame:	254TC	Mounting:	F1	Poles:	06	Created Date:	10-30-2006
Base:	N	Rotation:	R	Insulation:	F	Eff. Date:	10-08-2012
Leads:	9#12	Literature:		Elec. Diagram:		Replaced By:	

Nameplate NP1260E									
CAT.NO.	VECP2276T								
SPEC.	09H181X827								
HP	7.5								
VOLTS	230/460								
AMP	21.4/10.7								
RPM	1180								
FRAME	254TC	HZ	60	PH	3				
SER.F.	1.15	CODE	J	DES	B	CL	F		
NEMA-NOM-EFF	91.7	PF	71						
RATING	40C AMB-CONT								
CC	010A	USABLE AT 208V	25						
DE	6309	ODE	6309						
ENCL	TEFC	SN							

Parts List		
Part Number	Description	Quantity
SA150799	SA 09H181X827	1.000 EA
RA139650	RA 09H181X827	1.000 EA
09FN3001D01SP	EXTERNAL FAN, PLASTIC	1.000 EA
S/P107-000-005	SUPER-E PROC'S(254/6 FR.) ZK PLANT - POL	1.000 EA
09CB1002A12P	KOBX W/1.25 NPT LEAD HOLE & 2.38 MTG HOL	1.000 EA
09GS1010	GASKET, DWG, LEADWIRE SEPERATOR	1.000 EA
10XN2520K12	1/4-20 X.75 GRD 5	4.000 EA
HW1001A25	LOCKWASHER 1/4, ZINC PLT .493 OD, .255 I	4.000 EA
WD1000B17	KPA-8C BURNDY TERMINAL	1.000 EA
10XN2520K08	1/4-20 X .50 GRADE #5, STL, ZINC PLATE	1.000 EA
HW1001A25	LOCKWASHER 1/4, ZINC PLT .493 OD, .255 I	1.000 EA
HA3400A39	STUD- 3/8-16 X 6.19 OAL HEX WELKER	4.000 EA
HW1001A38	LOCKWASHER 3/8, ZINC PLT .688 OD, .382 I	4.000 EA
HA4017A08	.125X3.50 GREASER EXTEN. NLA	1.000 EA
HA4017A10	1/8X1.25 GREASE EXT (F/S)	1.000 EA
HW4019A01	PIPE COUPLING 1/8 NPT,STEEL,ZINC COATING	1.000 EA
HW5100A11	W3917-042 WVY WSHR (WB)	1.000 EA
10XN2520K28	1/4-20 X 1.75" HX HD SCRWGRADE 5, ZINC P	2.000 EA
09EP1300A12P	ENDPLATE, MACH EPOXY PRIMER	1.000 EA
10XN3816K24	3/8-16 X 1.50 HEX HD CAP SCREW, GRADE 5	4.000 EA
HW1001A38	LOCKWASHER 3/8, ZINC PLT .688 OD, .382 I	4.000 EA
10XN2520K36	1/4-20 X 2.25" HX HD SCRWGRADE 5, ZINC P	4.000 EA
09FH1000A03P	FAN HOUSING, MACH W/EPOXY PRIMER	1.000 EA
HW1001A38	LOCKWASHER 3/8, ZINC PLT .688 OD, .382 I	4.000 EA

Parts List (continued)		
Part Number	Description	Quantity
XY3816A12	3/8-16 FINISHED NUT	4.000 EA
09FH1500A01P	DRIP COVER, MACH W/EPOXY PRIMER	1.000 EA
10XN2520K26	1/4-20X 1 5/8 HEX HD, GRADE 5	4.000 EA
HW4600B44SP	V-RING SLINGER 1.500 X 2.290 X 0.280	1.000 EA
HW4600F87	V-RING VITON SLINGER T/D# VVA-045	1.000 EA
12CB1503A01P	KOLD MACH, W/LIP & EPOXY PRIMER	1.000 EA
12GS1002	GASKET, CONDUIT BOX LID, NEOP	1.000 EA
10XN3118K16	5/16-18 X 1" GRADE #5, STL, ZINC PLATE	2.000 EA
HW1001A31	LOCKWASHER 5/16, ZINC PLT.591 OD, .319 I	2.000 EA
HW2501G25	KEY, 3/8 SQ X 2.875	1.000 EA
MJ5001A01	46-665 RED SEALER	0.031 QT
MJ5001A14	DYNAPRO SEAL, CP MOTORS VC#2508050 (603	0.023 EA
LB1115	LABEL,LIFTING DEVICE	1.000 EA
LB1002	LABEL,MARINE DUTY (ON ROLLS)	1.000 EA
LB5040	INSTRUCTION TAG, AC & DC	1.000 EA
PK6014	STEEL STRAP FOR 309-312 BASELESS MOTORS	3.000 EA
19XW3118A08	.31-18 X .50 HEX WASHER HEAD TAPTITE II	3.000 EA
09EP1118A05GP6	FREP MACH, 309 BRG. EPOXY PRIMER	1.000 EA
HW4500A17	317400 ALEMITE GREASE RELIEF	1.000 EA
HW4500A05	1669B ALEM/UNIV860 GR FTG X	1.000 EA
HA4001A01SP	DRAIN PLUG, PLASTIC (MICRO PLAS)	1.000 EA
HA4051A00	PLASTIC CAP FOR GREASE FITTING	1.000 EA
HW2500A25	WOODRUFF KEY USA #1008 #BLOW CARBON STEE	1.000 EA
MJ1000A75	GREASE, POLYREX EM EXXON	0.080 LB

Parts List (continued)		
Part Number	Description	Quantity
HW4500A03	GREASE FITTING, .125 NPT 1610(ALEMITE) 8	1.000 EA
HW4500A17	317400 ALEMITE GREASE RELIEF	1.000 EA
HA4001A01SP	DRAIN PLUG, PLASTIC (MICRO PLAS)	1.000 EA
HA4051A00	PLASTIC CAP FOR GREASE FITTING	1.000 EA
51XB1214A20	12-14X1.25 HXWSSLD SERTYB	1.000 EA
MG1025N19	PAINT, 778.50 WILKO, RELIANCE ELEC GREEN	0.050 GA
85XU0407S04	4X1/4 U DRIVE PIN STAINLESS	2.000 EA
LB1125C02	SUPER-E (STOCK CTN LABEL SUPER-E WITH FL	4.000 EA
LB1357	ENERGY GUIDE LABEL (BOX LABEL)	1.000 SH
LC0005E02	SPL CONN.DIA./WARN.LABEL(LC0005/LB1119)	1.000 EA
NP1260E	SS CP SUPER-E UL CSA CC	1.000 EA
40PA1024	PKGP WOOD BASE, RISER SIDE LIFT GRUNDFOS	1.000 EA

Performance Data at 460V, 60Hz, 7.5HP (Typical performance - Not guaranteed values)

General Characteristics			
Full Load Torque:	32.4 LB-FT	Start Configuration:	DOL
No-Load Current:	5.84 Amps	Break-Down Torque:	99.2 LB-FT
Line-line Res. @ 25°C.:	0.89 Ohms A Ph / 0.0 Ohms B Ph	Pull-Up Torque:	39.4 LB-FT
Temp. Rise @ Rated Load:	31 C	Locked-Rotor Torque:	57.8 LB-FT
Temp. Rise @ S.F. Load:	36 C	Starting Current:	69.7 Amps

Load Characteristics							
% of Rated Load	25	50	75	100	125	150	S.F.
Power Factor:	32.0	52.0	63.0	70.0	73.0	75.0	72.0
Efficiency:	83.0	89.7	91.5	92.0	91.8	91.2	91.9
Speed:	1196.0	1192.0	1189.0	1184.0	1179.0	1173.0	1181.0
Line Amperes:	6.34	7.49	8.87	10.7	12.9	15.7	12.0

Performance Graph at 460V, 60Hz, 7.5HP Typical performance - Not guaranteed values

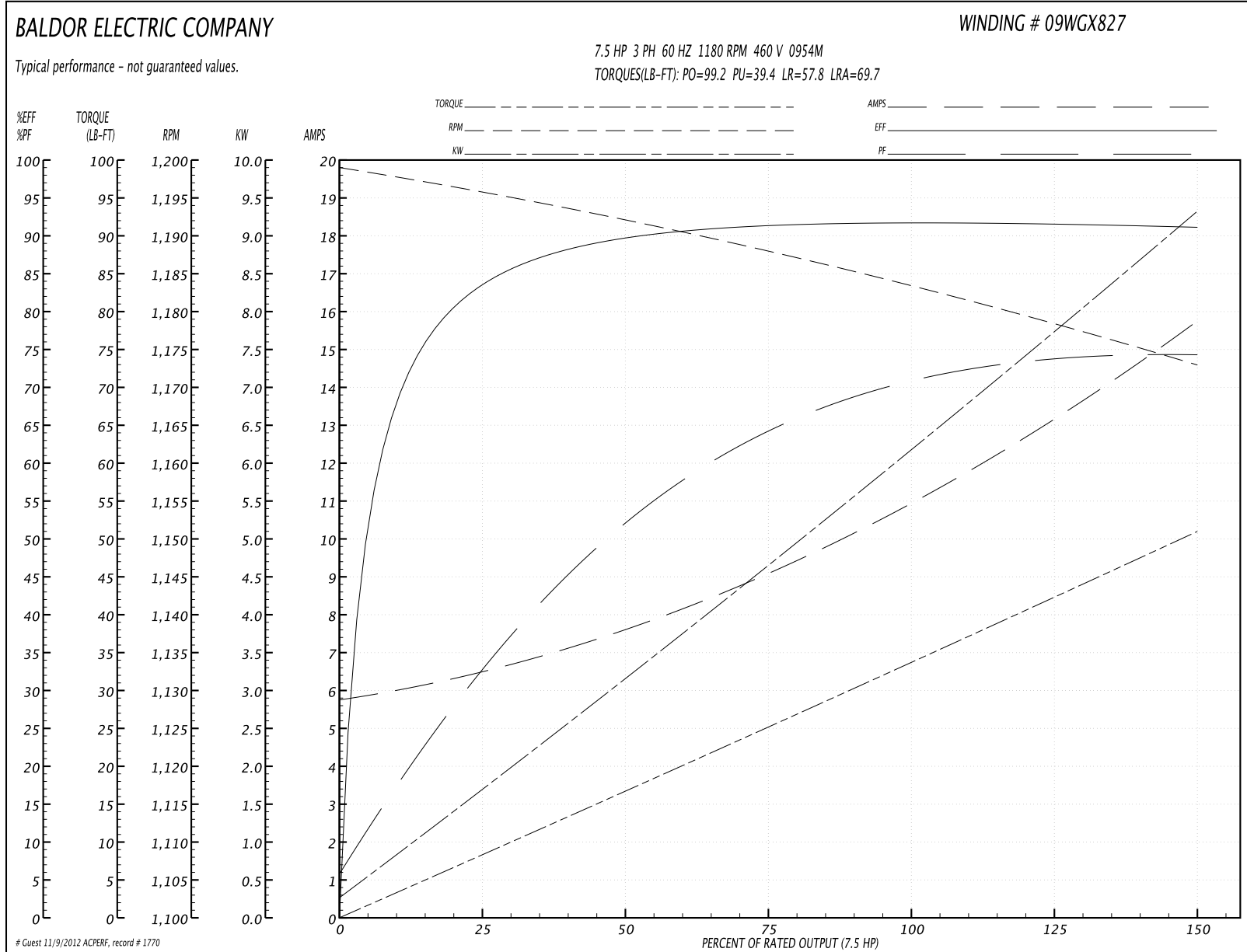

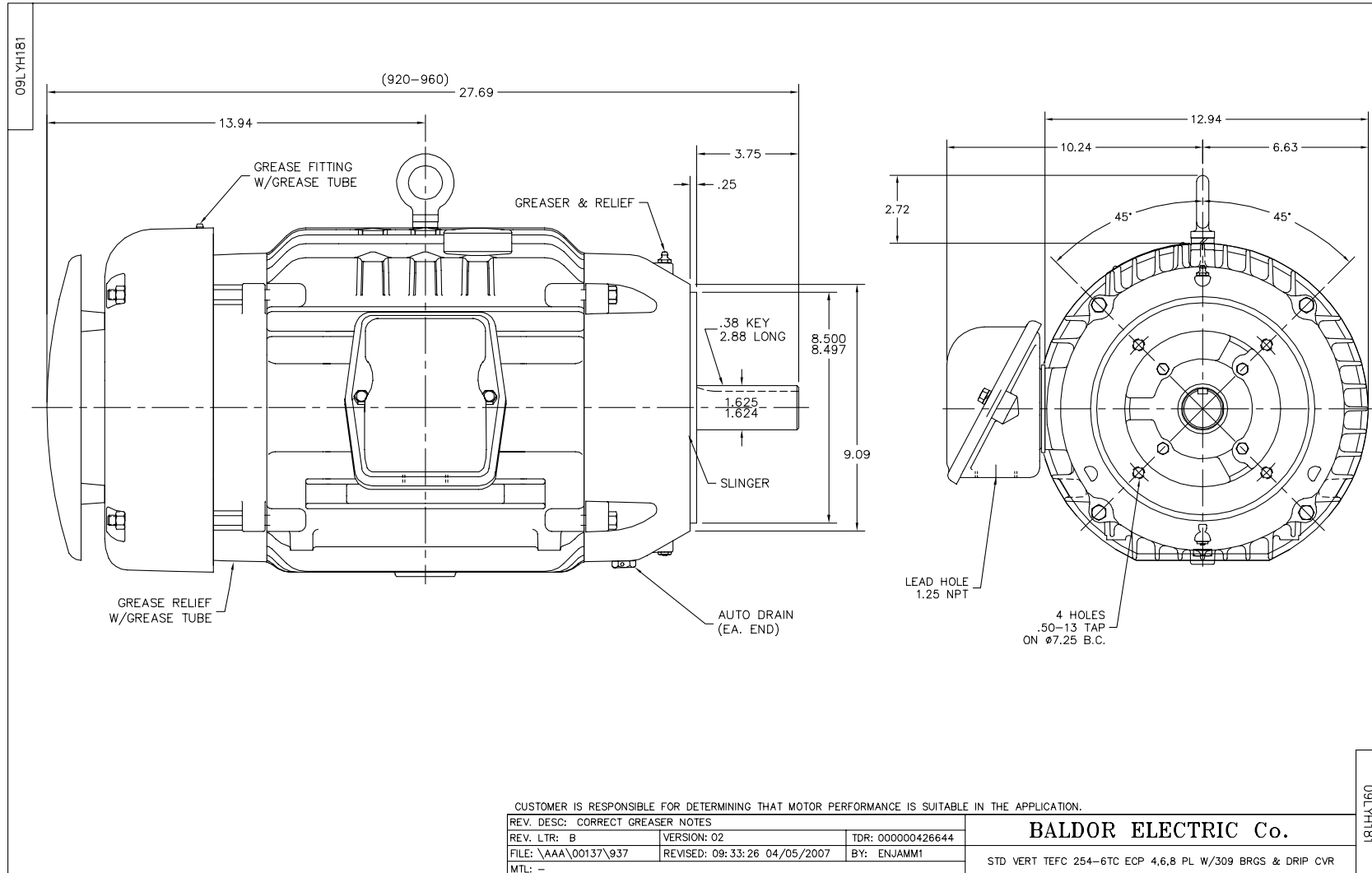

CD0005

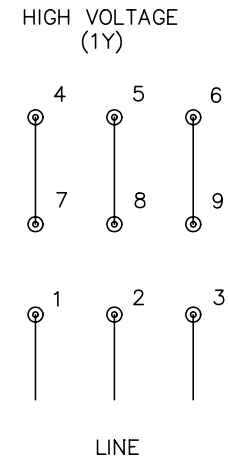
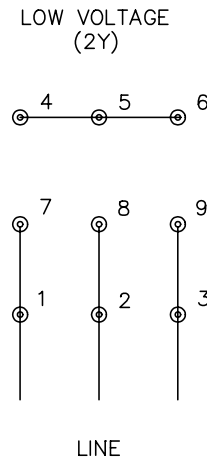
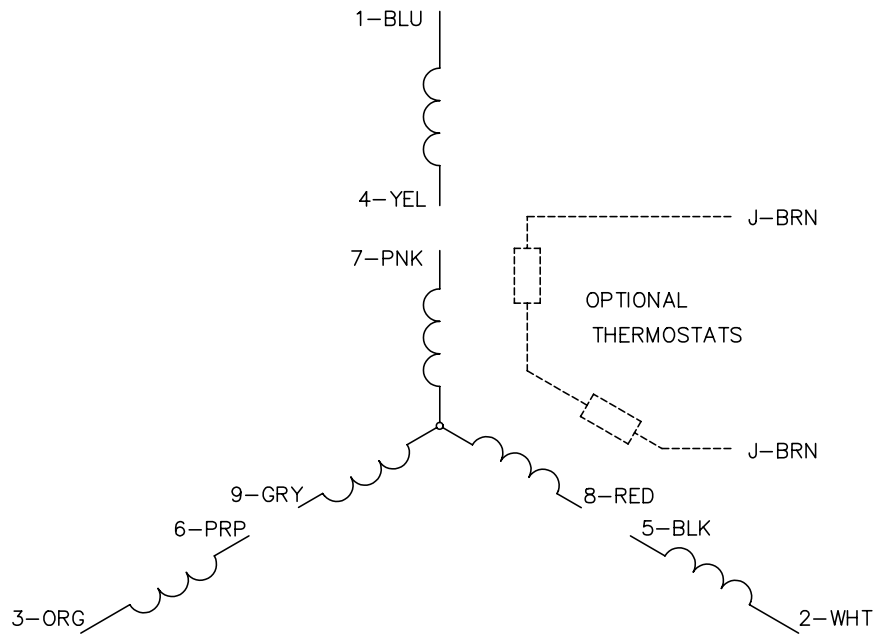

NOTES:

1. INTERCHANGE ANY TWO LINE LEADS TO REVERSE ROTATION.
2. OPTIONAL THERMOSTATS ARE PROVIDED WHEN SPECIFIED.
3. ACTUAL NUMBER OF INTERNAL PARALLEL CIRCUITS MAY BE A MULTIPLE OF THOSE SHOWN ABOVE.
4. LEAD COLORS ARE OPTIONAL. LEADS MUST ALWAYS BE NUMBERED AS SHOWN.

REV. DESC: REVISE TO SHOW OPTIONAL COLORS			
REV. LTR: E	BY: JLP	REVISED: 01/19/99 10:15	TDR: 0171435
90000		FILE: AAA00005140	MDL: -
		MTL: -	

BALDOR ELECTRIC Co.

3PH, DV, 9 LEADS

CD0005