

BALDOR® • **RELIANCE**

Product Information Packet

VECP83587T-4

2HP, 1755RPM, 3PH, 60HZ, 145TC, 0535M, TEFC, F1

Copyright © All product information within this document is subject to Baldor Electric Company copyright © protection, unless otherwise noted.

Part Detail							
Revision:	G	Status:	PRD/A	Change #:		Proprietary:	No
Type:	AC	Prod. Type:	0535M	Elec. Spec:	05WGW836	CD Diagram:	
Enclosure:	TEFC	Mfg Plant:		Mech. Spec:	05F161	Layout:	
Frame:	145TC	Mounting:	F1	Poles:	04	Created Date:	11-29-2010
Base:	N	Rotation:	R	Insulation:	F	Eff. Date:	09-26-2012
Leads:	3#18	Literature:		Elec. Diagram:		Replaced By:	

Nameplate NP2162E							
CAT.NO.	VECP83587T-4						
SPEC.	05F161W836G1						
HP	2	T. CODE	T3				
VOLTS	460						
AMP	2.8						
RPM	1755						
FRAME	145TC	HZ	60	PH	3		
SER.F.	1.15	CODE	L	DES	B	CL	F
NEMA-NOM-EFF	88.5	PF	75				
G.MIN.EFF	86.5	CC	010A				
RATING	40C AMB-CONT						
DE	6205	ODE	6205				
ENCL	TEFC	SN					

Nameplate NP2113E			
SPEC.	05F161W836G1		
MOTOR WEIGHT	67 LBS		
GREASE	POLYREX EM		
MAX. KVAR	.67		
# OF ROTOR BARS	28	# OF STATOR SLOTS	36
BLANK			
HTR-VOLTS	N/A	HTR-AMPS	N/A
MAX. SPACE HEATER TEMP.	N/A		

Parts List		
Part Number	Description	Quantity
SA212730	SA 05F161W836G1	1.000 EA
RA199959	RA 05F161W836G1	1.000 EA
34FN3002B01	EXTERNAL FAN, PLASTIC, .637/.639 HUB W/	1.000 EA
HW3201A05	3/8-16 EYEBOLT	1.000 EA
06CB1001A01G	CONDUIT BOX, MACH GRAY	1.000 EA
RM1016	LEAD SEPARATOR GASKET - 305/306 C.P.MOTO	1.000 EA
51XW2520A12	.25-20 X .75, TAPTITE II, HEX WSHR SLTD	2.000 EA
11XW1032G06	10-32 X .38, TAPTITE II, HEX WSHR SLTD U	1.000 EA
HW3001B01	003SS CUP WASHER, FOR #8 SCREW	1.000 EA
10XN2520S06	1/4 20X3/8 HX HD CAP S.S.	1.000 EA
WD1000B16	KPA-4C BURNDY TERMINAL	1.000 EA
51XN1032A20	10-32 X 1 1/4 HX WS SL SR	2.000 EA
05EP1100A03G	FREP TEFC 203,GRSR,RLF,NO DRAIN	1.000 EA
HW4601A22	INPRO SEAL, 205 BRG, VBX	1.000 EA
HW4600B36SP	V-RING SLINGER 1.188 X 1.690 X 0.240	1.000 EA
HW4500A01	1641B(ALEMITE)400 UNIV, GREASE FITT	1.000 EA
HA4051A00	PLASTIC CAP FOR GREASE FITTING	1.000 EA
HW4500A17	317400 ALEMITE GREASE RELIEF	1.000 EA
HW5100A05	WVY WSHR F/205 & 304 BRGS	1.000 EA
35EP1329A33G	EP ENCL,GRSR,RLF,(2).25-28 DRAINS, INPRO	1.000 EA
HW4601A22	INPRO SEAL, 205 BRG, VBX	1.000 EA
HW4600B36SP	V-RING SLINGER 1.188 X 1.690 X 0.240	1.000 EA
HW4500A01	1641B(ALEMITE)400 UNIV, GREASE FITT	1.000 EA
HA4051A00	PLASTIC CAP FOR GREASE FITTING	1.000 EA

Parts List (continued)		
Part Number	Description	Quantity
HW4500A17	317400 ALEMITE GREASE RELIEF	1.000 EA
HA4010A01	DRAIN PLUG,416 S.S.,W/ 1/4-28 THD & .076	2.000 EA
51XN1032A20	10-32 X 1 1/4 HX WS SL SR	2.000 EA
HA3100A28	THRUBOLT 10-32 X 8.187	4.000 EA
51XB1214A16	12-14X1.00 HXWSSLD SERTYB	1.000 EA
35FH1000A27G	35FH1000A27 W/GRAY FLUIDIZ	1.000 EA
10XN2520A16	1/4-20 X 1 HEX HEAD CAP SCR, ZINC PLATED	3.000 EA
HW1001A25	LOCKWASHER 1/4, ZINC PLT .493 OD, .255 I	3.000 EA
35FH4500A01	DRIP COVER, STAMPED X - W/AUTOPHORETIC P	1.000 EA
HA2001A13	35-10103 SPACER WELKER	3.000 EA
51XN1032A20	10-32 X 1 1/4 HX WS SL SR	3.000 EA
WD4100A03	DE-750 HEYCO PLUG 62MP0750 MICRO PLASTIC	1.000 EA
06CB1503A01G	LIPPED CONDUIT BOX LID, MACH GRAY EPOXY	1.000 EA
06GS1009	GASKET, KOBX LID, 1/8" THICK BLACK NEOPR	1.000 EA
10XN2520A12	O1/4-20X 3/4 HEX HEAD CAP	2.000 EA
HW1001A25	LOCKWASHER 1/4, ZINC PLT .493 OD, .255 I	2.000 EA
HW2501D13SP	KEY, 3/16 SQ X 1.375	1.000 EA
HA7000A01	KEY RETAINER 7/8" DIA SHAFT	1.000 EA
MJ5004A59	ADHESIVE LOCTITE #401 SURFACE INSENSITIV	0.010 EA
MJ5001A01	46-665 RED SEALER	0.001 QT
MJ1000A73	INPRO P-80 ASSEMBLY LUB./ 1 QT. CONTAIN	0.001 QT
85XU0407S04	4X1/4 U DRIVE PIN STAINLESS	4.000 EA
LB1002	LABEL,MARINE DUTY (ON ROLLS)	1.000 EA
LB1115	LABEL,LIFTING DEVICE	1.000 EA

Parts List (continued)		
Part Number	Description	Quantity
LT0019A00	MOTOR NO-LOAD PERFORMANCE DATA SHEET	1.000 EA
WD1000D21	TRM,T&B #B71M,RING,18-14,.25,NON-INSL	3.000 EA
MJ1000A75	GREASE, POLYREX EM EXXON	0.050 LB
MG1025N19	PAINT, 778.50 WILKO, RELIANCE ELEC GREEN	0.010 GA
LB1119	WARNING LABEL	1.000 EA
LB1125C02	SUPER-E (STOCK CTN LABEL SUPER-E WITH FL	1.000 EA
LB1357	ENERGY GUIDE LABEL (BOX LABEL)	1.000 SH
LC0006	CONNECTION LABEL	1.000 EA
LB1449	DIV-2/NEC WARNING LABEL	1.000 EA
NP2162E	SS IEEE841 DIV-2 UL CSA-C US EEV PREM	1.000 EA
NP2113E	SS IEEE841 AUX DATA INFORMATION SURFACE	1.000 EA
36PA1001	PACKAGING GROUP	1.000 EA
PK3082	STYROFOAM CRADLE	1.000 EA

Performance Data at 460V, 60Hz, 2.0HP (Typical performance - Not guaranteed values)

General Characteristics							
Full Load Torque:	6.01 LB-FT			Start Configuration:	DOL		
No-Load Current:	1.64 Amps			Break-Down Torque:	26.6 LB-FT		
Line-line Res. @ 25°C.:	6.46 Ohms A Ph / 0.0 Ohms B Ph			Pull-Up Torque:	20.5 LB-FT		
Temp. Rise @ Rated Load:	38 C			Locked-Rotor Torque:	21.6 LB-FT		
Temp. Rise @ S.F. Load:	47 C			Starting Current:	25.0 Amps		
Load Characteristics							
% of Rated Load	25	50	75	100	125	150	S.F.
Power Factor:	34.0	54.0	67.0	75.0	80.0	83.0	78.0
Efficiency:	80.0	86.9	88.5	88.6	87.9	86.8	88.2
Speed:	1790.0	1779.0	1768.0	1756.0	1743.0	1729.0	1748.0
Line Amperes:	1.74	2.01	2.39	2.83	3.34	3.88	3.14

Performance Graph at 460V, 60Hz, 2.0HP Typical performance - Not guaranteed values

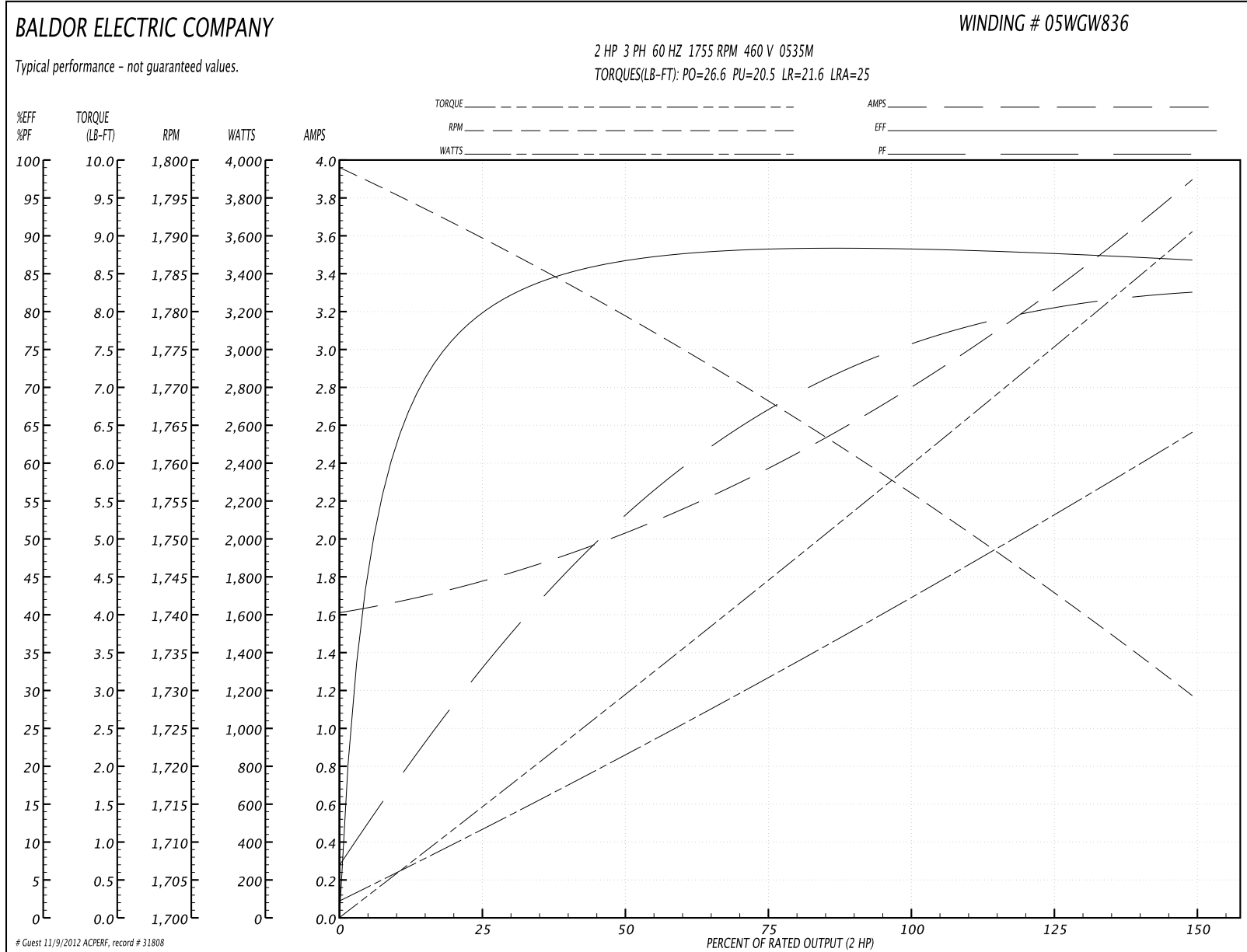

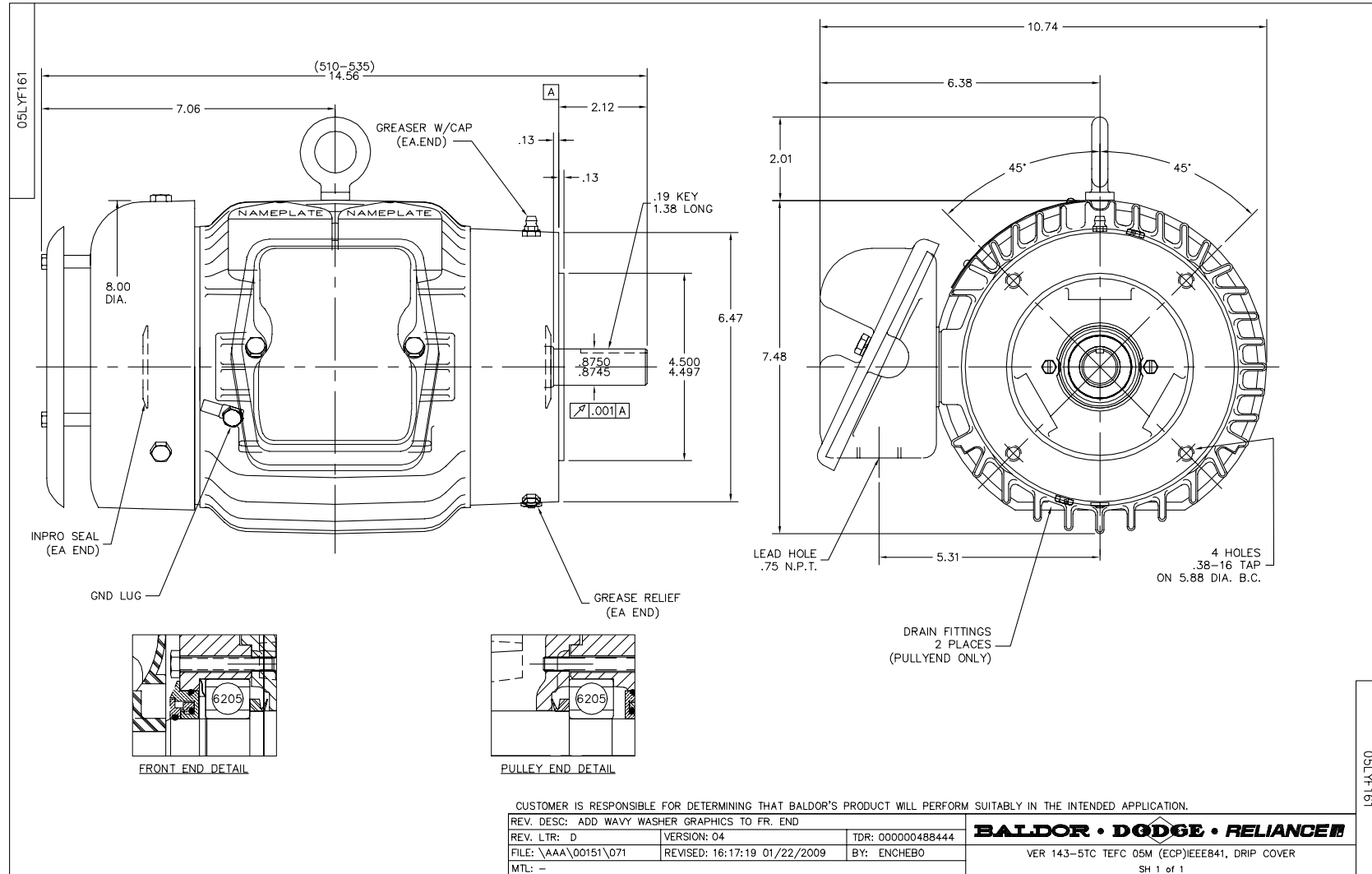

CD0006

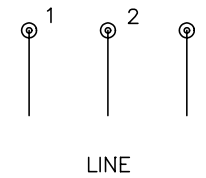
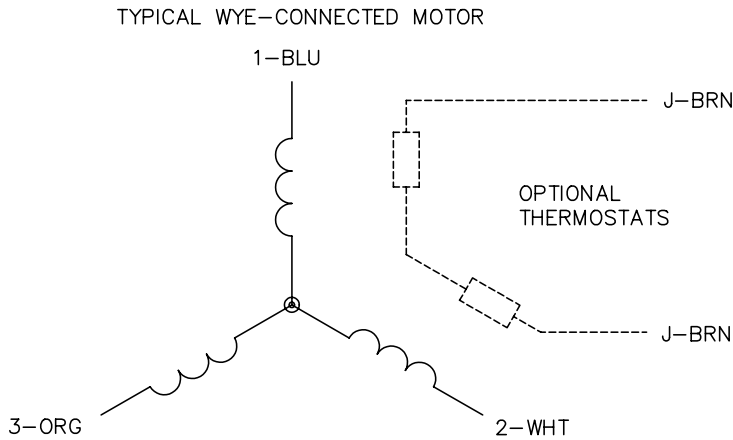

NOTES:

1. THREE LEAD MOTOR MAY BE EITHER WYE CONNECTED OR DELTA CONNECTED.
2. INTERCHANGE ANY TWO LINE LEADS TO REVERSE ROTATION.
3. OPTIONAL THERMOSTATS ARE PROVIDED WHEN SPECIFIED.
4. ACTUAL NUMBER OF INTERNAL PARALLEL CIRCUITS MAY VARY.
5. LEAD COLORS ARE OPTIONAL. LEADS MUST BE NUMBERED AS SHOWN.

REV. DESC: REVISE TO SHOW OPTIONAL COLORS			
REV. LTR: D	BY: JLP	REVISED: 01/21/99 4:02	TDR: 0171435
9000D		FILE: AAA00005141	MDL: -
		MTL: -	

BALDOR ELECTRIC Co.

3PH, SV, 3 LEADS, WYE OR DELTA CONNECTED

CD0006