

# **BALDOR**® • *RELIANCE*

## **Product Information Packet**

# **VHECP3661T**

**3HP, 1755RPM, 3PH, 60HZ, 182HP, 0632M, TEFC, F1**

Copyright © All product information within this document is subject to Baldor Electric Company copyright © protection, unless otherwise noted.

Part Detail									
Revision:	-	Status:	PRD/A	Change #:		Proprietary:	No		
Type:	AC	Prod. Type:	0632M	Elec. Spec:	06WGX181	CD Diagram:			
Enclosure:	TEFC	Mfg Plant:		Mech. Spec:	06F448	Layout:			
Frame:	182HP	Mounting:	F1	Poles:	04	Created Date:	10-04-2011		
Base:	N	Rotation:	R	Insulation:	F	Eff. Date:	10-07-2011		
Leads:	9#16	Literature:		Elec. Diagram:		Replaced By:			
Nameplate NP1260E									
CAT.NO.	VHECP3661T								
SPEC.	06F448X181G1								
HP	3								
VOLTS	208-230/460								
AMP	8.6-8.2/4.1								
RPM	1755								
FRAME	182HP	HZ	60			PH	3		
SER.F.	1.15	CODE	J			DES	B	CL	F
NEMA-NOM-EFF	89.5	PF	77						
RATING	40C AMB-CONT								
CC	010A	USABLE AT 208V							
DE	6307	ODE	6206						
ENCL	TEFC	SN							

Parts List		
Part Number	Description	Quantity
SA231977	SA 06F448X181G1	1.000 EA
RA218987	RA 06F448X181G1	1.000 EA
36FN3000C01SP	EXFN, PLASTIC, 5.25 OD, .912 ID	1.000 EA
S/P107-000-001	SUPER E PROC'S-FS & WS PLTS-POLYREX EM G	1.000 EA
09CB1501A05G	CONDUIT BOX, 1.00 NPT @6,(GRAY)(AQUA AER	1.000 EA
RM1016	LEAD SEPARATOR GASKET - 305/306 C.P.MOTO	1.000 EA
51XW2520A12	.25-20 X .75, TAPTITE II, HEX WSHR SLTD	2.000 EA
WD1000B16	KPA-4C BURNDY TERMINAL	2.000 EA
10XN2520G06	1/4 20X3/8 HX HD CAP, GREEN	2.000 EA
HW1001S25	WASHER, 1/4 SPLT LK, STAINLESS STEEL	2.000 EA
36EP1100A25G	FREP ENCL. 206 BRG.,GRSR,REL,#26 DRAIN(G	1.000 EA
HW4500A32	FIT./EXT 1698-B (ALEMITE)GREASE FITTING	1.000 EA
HW4500A17	317400 ALEMITE GREASE RELIEF	1.000 EA
HW5100A06	W2420-025 WVY WSHR (WB)	1.000 EA
36EP1505A02G	SPL PU E.P. - ENCL.- 307 BRG - NEMA 182L	1.000 EA
HW4500A01	1641B(ALEMITE)400 UNIV, GREASE FITT	1.000 EA
HW4500A17	317400 ALEMITE GREASE RELIEF	1.000 EA
12XN1032S22	10-32 X 1 3/8 SLOT HEX, STAINLESS STEEL	2.000 EA
10XN2520S48	1/4-20 X 3 HEX HEAD SS	2.000 EA
HA3101S46	THRUBOLT- 1/4-20 X 10.00 SS	4.000 EA
51XB1214A16	12-14X1.00 HXWSSLD SERTYB	1.000 EA
06FH1004A26G	FAN HOUSING MACH, W/GREASER AND DRIP CVR	1.000 EA
10XN2520S24	1/4-20X 1 1/2 HEX HD SS	3.000 EA
39FH4500A03G	DRIP COVER, STAMPED (GRAY EPOXY)	1.000 EA

Parts List (continued)		
Part Number	Description	Quantity
XY3816S12	3/8-16 HEX FINISHED NUT SS	2.000 EA
HA3400S09	STUD-3/8-16 X 2.75	4.000 EA
HW1001S38	WASHER, 3/8 SPLT LK, STAINLESS STEEL	6.000 EA
HW3208S01	3/8-16 EYE NUT	2.000 EA
HW4600A47	CR#13535--NAT#472354 OR TRANSCOM	1.000 EA
HW4600A55	SEAL 1.625 X 2.125 X 0.250 SINGLE LIP	1.000 EA
09CB1504A01G	LIPPED CONDUIT BOX LID, MACH GRAY EPOXY	1.000 EA
09GS1001A01SP	GASKET, BOX LID, 1/8 THICK BLACK NEOPREN	1.000 EA
10XN2520S12	BOLT 1/4 - 20X 3/4 HEX HEAD SS (F/S)	2.000 EA
HW1001S25	WASHER, 1/4 SPLT LK, STAINLESS STEEL	2.000 EA
HW4600B36SP	V-RING SLINGER 1.188 X 1.690 X 0.240	1.000 EA
HW4600B56	SEAL 1.250 X 1.770 X 0.240 FACE SEALING	1.000 EA
HW2502E16	#303 SS,SQ KEY 1/4 X 1.750	1.000 EA
HA7000A02	KEY RETAINER RING, 1 1/8 DIA, 1 3/8 DIA	1.000 EA
MJ5001A01	46-665 RED SEALER	0.001 QT
MJ5001A14	DYNAPRO SEAL, CP MOTORS VC#2508050 (603	0.001 EA
LB1002	LABEL,MARINE DUTY (ON ROLLS)	1.000 EA
LB1115	LABEL,LIFTING DEVICE	1.000 EA
85XU0407S04	4X1/4 U DRIVE PIN STAINLESS	2.000 EA
MJ1000A75	GREASE, POLYREX EM EXXON	0.050 LB
MG1025Z20	ACTIVATOR WILKOFAS 060.32	0.010 GA
MG1025G29	PAINT 789.205 DARK GRAY METALLIC (USE W/	0.028 GA
LC0005E01	CONN.DIA./WARNING LABEL (LC0005/LB1119)	1.000 EA
LB1125C02	SUPER-E (STOCK CTN LABEL SUPER-E WITH FL	1.000 EA

Parts List (continued)		
Part Number	Description	Quantity
LB1357	ENERGY GUIDE LABEL (BOX LABEL)	1.000 SH
NP1260E	SS CP SUPER-E UL CSA CC	1.000 EA
G0PA1000	PACKAGING GROUP	1.000 EA
PK3082	STYROFOAM CRADLE	2.000 EA
PK6503	STRUCTURAL WOOD PSC 1X6X8MULLBERRY LUMBE	1.000 EA

**Performance Data at 460V, 60Hz, 3.0HP (Typical performance - Not guaranteed values)**

General Characteristics							
Full Load Torque:	9.06 LB-FT			Start Configuration:	DOL		
No-Load Current:	2.14 Amps			Break-Down Torque:	33.1 LB-FT		
Line-line Res. @ 25°C.:	3.92 Ohms A Ph / 0.0 Ohms B Ph			Pull-Up Torque:	18.2 LB-FT		
Temp. Rise @ Rated Load:	35 C			Locked-Rotor Torque:	20.4 LB-FT		
Temp. Rise @ S.F. Load:	42 C			Starting Current:	29.8 Amps		
Load Characteristics							
% of Rated Load	25	50	75	100	125	150	S.F.
Power Factor:	38.0	58.0	70.0	77.0	81.0	83.0	79.0
Efficiency:	83.6	88.9	90.1	89.9	89.1	87.8	89.4
Speed:	1789.5	1779.3	1768.8	1757.0	1744.4	1730.0	1749.0
Line Amperes:	2.34	2.79	3.39	4.1	4.91	5.86	4.59

Performance Graph at 460V, 60Hz, 3.0HP Typical performance - Not guaranteed values

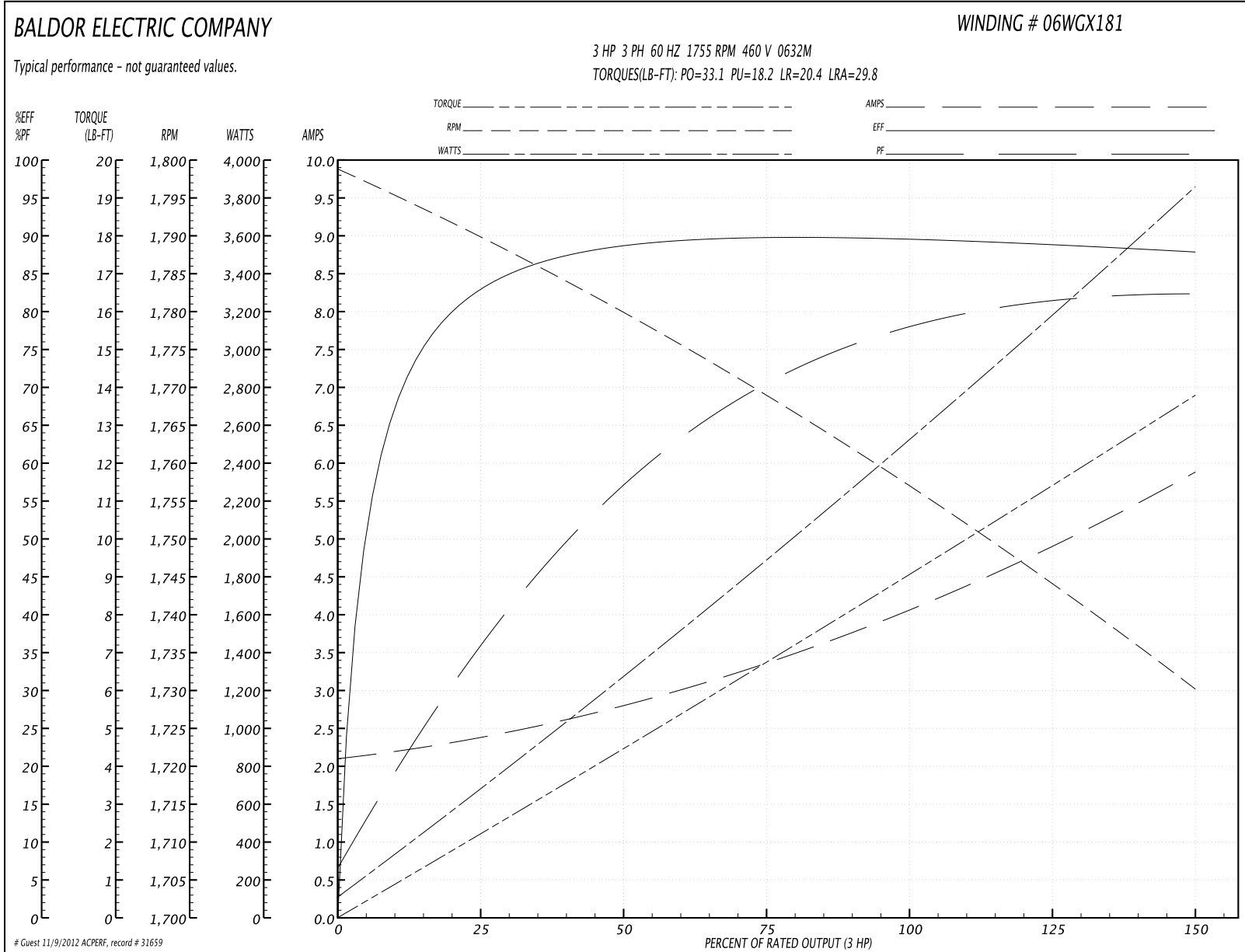

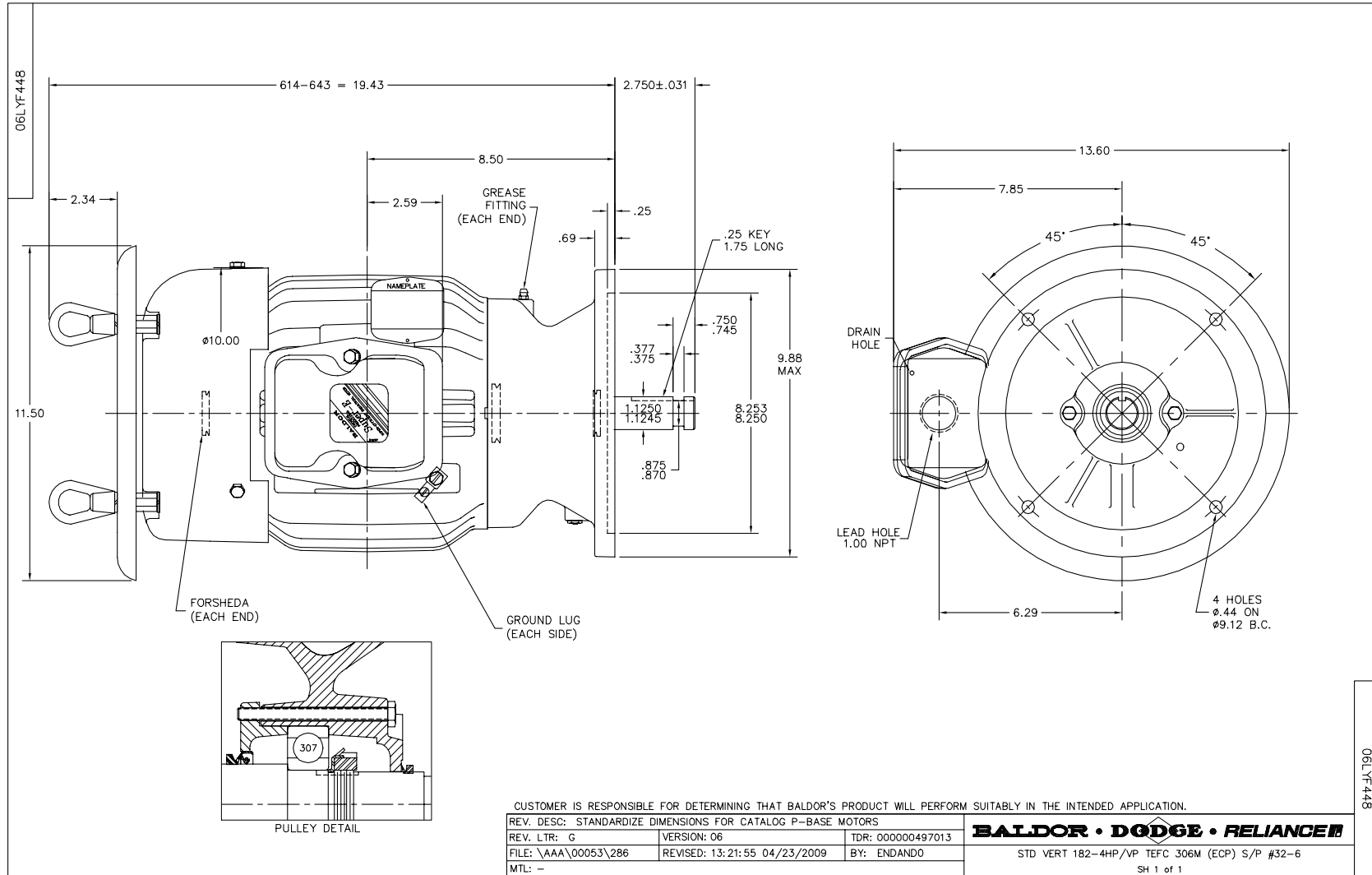



CD0005



LOW VOLTAGE  
(2Y)



LINE

HIGH VOLTAGE  
(1Y)



LINE

NOTES:

1. INTERCHANGE ANY TWO LINE LEADS TO REVERSE ROTATION.
2. OPTIONAL THERMOSTATS ARE PROVIDED WHEN SPECIFIED.
3. ACTUAL NUMBER OF INTERNAL PARALLEL CIRCUITS MAY BE A MULTIPLE OF THOSE SHOWN ABOVE.
4. LEAD COLORS ARE OPTIONAL. LEADS MUST ALWAYS BE NUMBERED AS SHOWN.

REV. DESC: REVISE TO SHOW OPTIONAL COLORS			
REV. LTR: E	BY: JLP	REVISED: 01/19/99 10:15	TDR: 0171435
90000		FILE: AAA00005140	MDL: -
		MTL: -	

**BALDOR ELECTRIC Co.**

3PH, DV, 9 LEADS

CD0005