

# **BALDOR® • RELIANCE**

## **Product Information Packet**

### **VP3585-14**

**1.5/2HP, 1750RPM, DC, D90C, 3548P, TEFC, F2**

Copyright © All product information within this document is subject to Baldor Electric Company copyright © protection, unless otherwise noted.

Part Detail							
Revision:	AA	Status:	PRD/A	Change #:		Proprietary:	No
Type:	DC	Prod. Type:		Elec. Spec:	35WGZ170	CD Diagram:	
Enclosure:	TEFC	Mfg Plant:		Mech. Spec:	35P454	Layout:	
Frame:	D90C	Mounting:	F2	Poles:	///	Created Date:	
Base:	RG	Rotation:	R	Insulation:	F	Eff. Date:	04-05-2012
Field Type:		Literature:		Elec. Diagram:		Replaced By:	
Nameplate NP1049L							
CAT.NO.	VP3585-14						
SPEC.	35P454Z170						
KW/HP	1.5/2	TE		I.P.		54	
RPM	1750	TE					
IEC FRAME	D90C			TYPE		3548P	
ARM V	180			ARM A		9.6	
FLD V				FLD A			
INSUL	F			AMB.		40	
DUTY	CONT			SUPPLY		K	
BRG/DE	6206			BRG/ODE		6205	
BRUSHES	2/BP5000T15						
				BLANK			
SER.							
BLANK							
APRV-CE				APRV-CSA			APRV-UL

Parts List		
Part Number	Description	Quantity
SA005514	SA 35P454Z170	1.000 EA
AA003163	AA 35P454Z170	1.000 EA
BP5000T15SP	CARBON BRUSH-35P,180VOLTS	1.000 EA
11XW1032G06	10-32 X .38, TAPTITE II, HEX WSHR SLTD U	1.000 EA
HW3001B01	003SS CUP WASHER, FOR #8 SCREW	1.000 EA
HW1003A10	WASHER, #10 EX TH LK, ZN X	1.000 EA
35EP3110A04	STD FR EP TEFC F2 MTG FOR EXT T'BOLT 35P	1.000 EA
HW5100A05	WVY WSHR F/205 & 304 BRGS	1.000 EA
35EP1512A03	PU ENDPLATE IEC D90C B14 MTG 206 BRG -E	1.000 EA
HW4600B50SP	SEAL 1.156 X 1.874 X 0.250 SINGLE LIP DB	1.000 EA
51XN1032A24	10-32 X 1 1/2 HX WS SL SR	2.000 EA
BP5201A14SP	BRUSH HOLDER ASSY	1.000 EA
80XN1032A03	10-32 X 3/16 SET SCREW	2.000 EA
MJ5004A05	#242-21 LOCTITE GENERAL PURPOSE MED. STR	0.001 EA
35FN3002A05SP	EXFN, PLASTIC, 6.376 OD, .638 ID	1.000 EA
51XB1214A16	12-14X1.00 HXWSSLD SERTYB	1.000 EA
35FH5001A10SP	FAN COVER ASS'Y TEFC HORZ	1.000 EA
51XW1032A06	10-32 X .38, TAPTITE II, HEX WSHR SLTD S	3.000 EA
WD4102A01	SR-6L-1 HEYCO STRN RELIEF OR 23MPO6L10 M	1.000 EA
WD4100A17	PLUG STIMPSON D4036	1.000 EA
35CB4506	CONDUIT BOX LID, STAMPED	1.000 EA
35GS1010	CONDUIT BOX LID, GASKET	1.000 EA
51XW0832A07	8-32 X .44, TAPTITE II, HEX WSHR SLTD SE	2.000 EA
HW2505A14	KEY, 8 X 7 MM 1.50 INCHES	1.000 EA

Parts List (continued)		
Part Number	Description	Quantity
HA7000A12	KEY RETAINER 0.945-1.00 DIA SHAFTS	1.000 EA
MJ5001A01	46-665 RED SEALER	0.001 QT
MG1000G27	PAINT- S9282E CHARCOAL GREY	0.017 GA
10XF0440S02	04-40 X 1/8 TYPE F HEX HD STAINLESS STIC	2.000 EA
HA3101A25	THRUBOLT 1/4-20 X 11.000 OHIO ROD	4.000 EA
LB1119	WARNING LABEL	1.000 EA
LB1125C01	STD (STOCK) CARTON LABEL BALDOR WITH FLA	1.000 EA
LB5040	INSTRUCTION TAG, AC & DC	1.000 EA
LC0194	CONNECTION LABEL FOR TYPE PM-DC MOTOR W/	1.000 EA
NP1049L	NP STD LASER ENGRAVED IEC DC MOTORS, UL	1.000 EA
35PA1007	PACKAGING GROUP	1.000 EA

Accessories		
Part Number	Description	Multiplier
TK3500	TACHO MOUTING KIT TK3500	A8

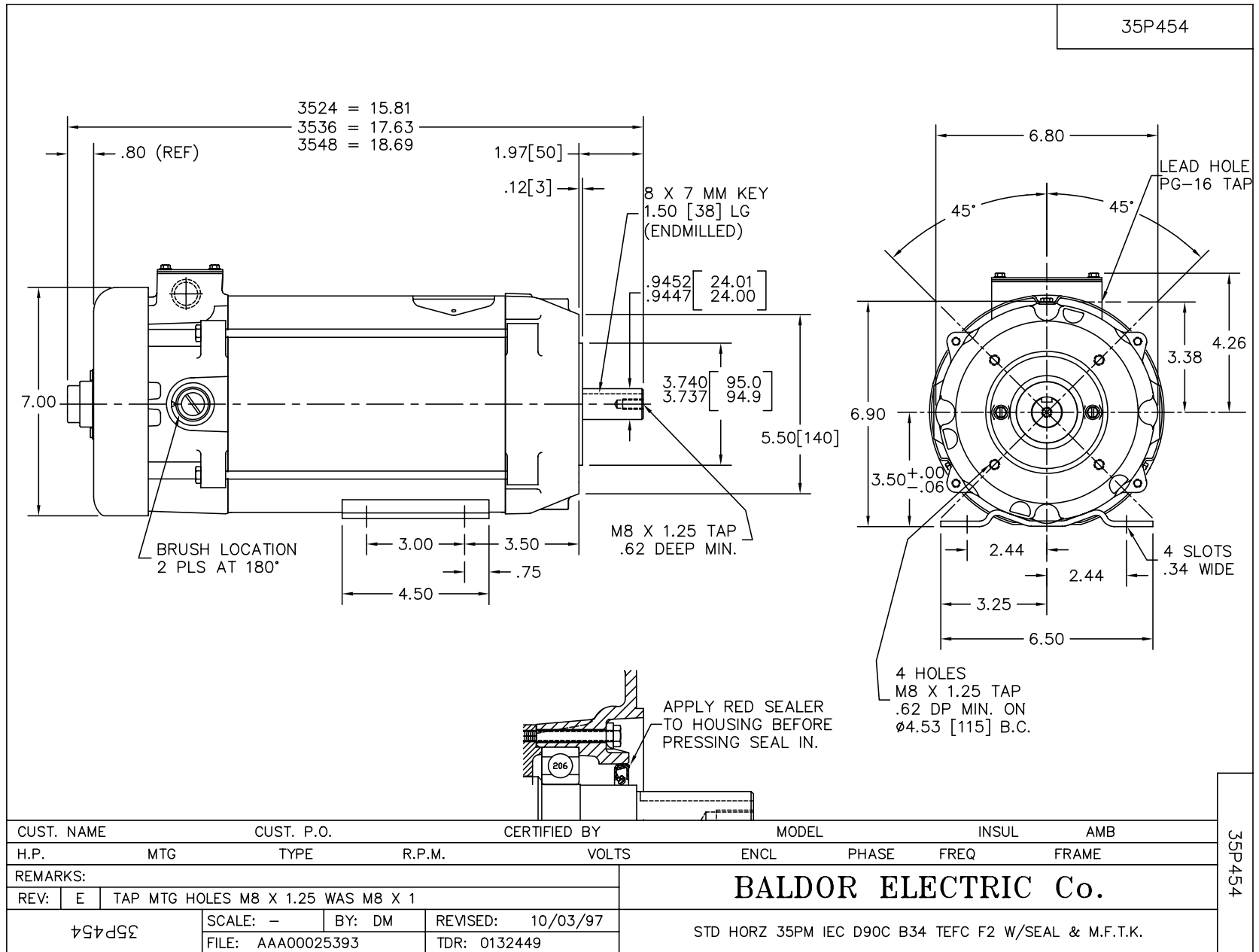

CD0194

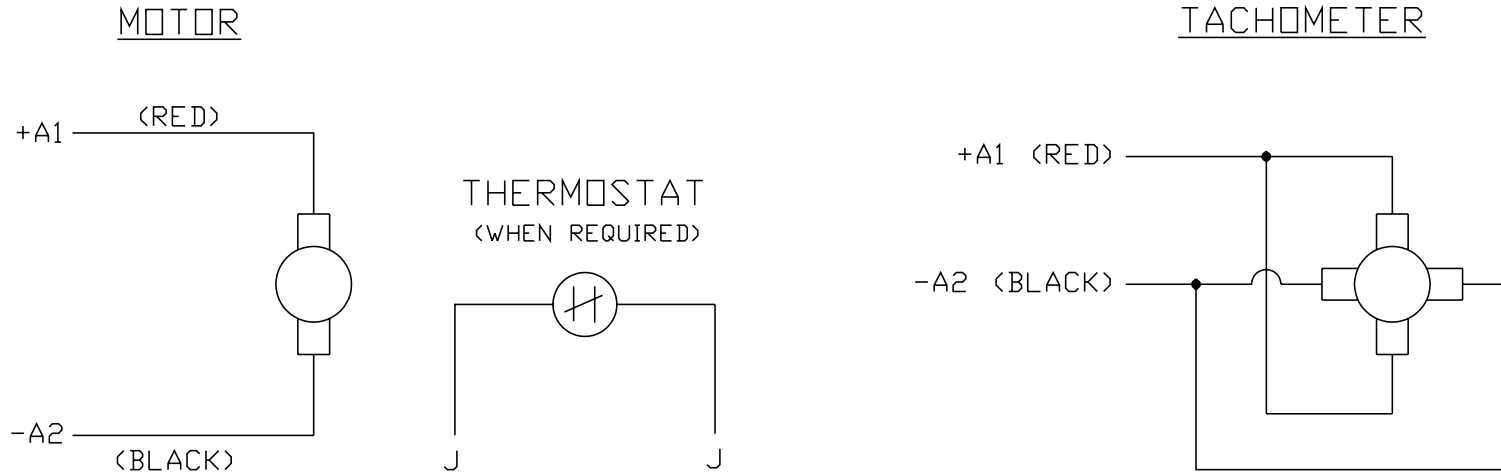

NOTES:

1. CCW ROTATION AS SHOWN FACING COMMUTATOR END. TO REVERSE MOTOR ROTATION OR TACHOMETER OUTPUT POLARITY INTERCHANGE LEADS A1(RED) & A2(BLACK)
2. LEAD COLORS FOR REFERENCE ONLY & NOT SPECIFIED BY THIS DRAWING. LEAD COLORS SPECIFIED BY LAYOUT DRAWING & BILL OF MATERIAL ONLY.

MATL: -			
REV: E	ADDED NOTE "LEAD COLORS FOR REFERENCE ONLY &..."		
761000	SCALE: -	BY: CK	REVISED: 07/28/95
	FILE: AAA00004503		TDR: 0078737

**BALDOR ELECTRIC Co.**

CD TYPE P DC PERMANENT MAGNET MOTORS AND TACHOMETERS

CD0194