

# **BALDOR**® • *RELIANCE*

## **Product Information Packet**

# **WCL1409T**

**5HP,3450RPM,1PH,60HZ,184TCZ,3634L,OPEN**

Copyright © All product information within this document is subject to Baldor Electric Company copyright © protection, unless otherwise noted.

Part Detail							
Revision:	Y	Status:	PRD/A	Change #:		Proprietary:	No
Type:	AC	Prod. Type:	3634L	Elec. Spec:	36WG0190	CD Diagram:	
Enclosure:	OPEN	Mfg Plant:		Mech. Spec:	36E775	Layout:	
Frame:	184TCZ	Mounting:	F1	Poles:	02	Created Date:	
Base:	RG	Rotation:	R	Insulation:	F	Eff. Date:	05-06-2011
Leads:	2#10 A PH,2#16 B PH	Literature:		Elec. Diagram:		Replaced By:	

Nameplate NP1256L									
CAT.NO.	WCL1409T								
SPEC.	36E775-190								
HP	5								
VOLTS	230								
AMP	23								
RPM	3450								
FRAME	184TCZ	HZ	60	PH	1				
SER.F.	1.15	CODE	F	DES	L	CLASS	F		
NEMA-NOM-EFF	75	PF	88						
RATING	40C AMB-CONT								
CC				USABLE AT 208V	24				
DE	6207	ODE	6205						
ENCL	OPEN	SN							

Parts List		
Part Number	Description	Quantity
SA034725	SA 36E775-190	1.000 EA
RA030753	RA 36E775-190	1.000 EA
36CB3004	36 CB CASTING W/1.09 DIA LEAD HOLE @ 6:0	1.000 EA
51XB1016A08	10-16X 1/2HXWSSLD SERTYB	2.000 EA
11XW1032G06	10-32 X .38, TAPTITE II, HEX WSHR SLTD U	1.000 EA
HW3001B01	003SS CUP WASHER, FOR #8 SCREW	1.000 EA
36EP3200A25	FR ENDPLATE, MACH	1.000 EA
HW4500A01	1641B(ALEMITE)400 UNIV, GREASE FITT	1.000 EA
HW4500A17	317400 ALEMITE GREASE RELIEF	1.000 EA
HA1103A08	RODENT SCREEN, 36 FRAME, OPEN, FRONT END	1.000 EA
51XW1032A06	10-32 X .38, TAPTITE II, HEX WSHR SLTD S	4.000 EA
HW1000A10	#10 FLAT WASHER (SAE)	4.000 EA
HW1000A10	#10 FLAT WASHER (SAE)	4.000 EA
SP1008A01	BAFFLE, MODEL 36 & 37	1.000 EA
13XF0832A08	8-32 X.50 PAN HD,SLTD, TYPE F SCREW, ZIN	2.000 EA
10XN2520A12	O1/4-20X 3/4 HEX HEAD CAP	2.000 EA
HW5100A05	WVY WSHR F/205 & 304 BRGS	1.000 EA
36EP1206A15	PU ENDPLATE, MACH	1.000 EA
HW4500A01	1641B(ALEMITE)400 UNIV, GREASE FITT	1.000 EA
HW4500A17	317400 ALEMITE GREASE RELIEF	1.000 EA
36AD2000	AIR BAFFLE	1.000 EA
85XU0407S04	4X1/4 U DRIVE PIN STAINLESS	4.000 EA
HA1102A09	RODENT SCREEN 36 OPEN FAC	2.000 EA
51XW1032A06	10-32 X .38, TAPTITE II, HEX WSHR SLTD S	4.000 EA

Parts List (continued)		
Part Number	Description	Quantity
10XN2520A26	1/4-20X 1 5/8 HEX HD	4.000 EA
HW1001A25	LOCKWASHER 1/4, ZINC PLT .493 OD, .255 I	4.000 EA
36CB4516	36 LIPPED CB LID	1.000 EA
51XW0832A07	8-32 X .44, TAPTITE II, HEX WSHR SLTD SE	4.000 EA
HA2009A01	36-4613 SL ANOD. ALUM (STER	1.000 EA
80XN1032A06	10-32 X 3/8 SET SC HEX SOCK	1.000 EA
HW2501D13SP	KEY, 3/16 SQ X 1.375	1.000 EA
HA7000A01	KEY RETAINER 7/8" DIA SHAFT	1.000 EA
85XU0407S04	4X1/4 U DRIVE PIN STAINLESS	2.000 EA
MJ1000A75	GREASE, POLYREX EM EXXON	0.050 LB
MG1000G27	PAINT- S9282E CHARCOAL GREY	0.022 GA
SP5061A03	MODEL 36 TYPE L,F1,LARGE CAP BOX	1.000 EA
36CB5008A01	CAPACITOR BOX KIT, 36CB3800, EC1216C06	1.000 EA
HA3101A25	THRUBOLT 1/4-20 X 11.000 OHIO ROD	4.000 EA
LB1119	WARNING LABEL	1.000 EA
LB1125C01	STD (STOCK) CARTON LABEL BALDOR WITH FLA	1.000 EA
LC0017	CONN LABEL-1 PHASE-SINGLE VOLT-REV ROTNO	1.000 EA
NP1256L	ALUM UL CSA CC	1.000 EA
G0PA1000	PACKAGING GROUP	1.000 EA

**Performance Data at 230V, 60Hz, 5.0HP (Typical performance - Not guaranteed values)**

General Characteristics							
Full Load Torque:	7.6 LB-FT			Start Configuration:	DOL		
No-Load Current:	9.0 Amps			Break-Down Torque:	18.7 LB-FT		
Line-line Res. @ 25°C.:	0.338 Ohms A Ph / 1.16 Ohms B Ph			Pull-Up Torque:	16.0 LB-FT		
Temp. Rise @ Rated Load:	75 C			Locked-Rotor Torque:	18.0 LB-FT		
Temp. Rise @ S.F. Load:	90 C			Starting Current:	125.0 Amps		
Load Characteristics							
% of Rated Load	25	50	75	100	125	150	S.F.
Power Factor:	59.0	76.0	84.0	88.0	90.0	90.0	0.0
Efficiency:	63.0	74.5	77.7	78.0	76.5	73.6	0.0
Speed:	3559.0	3524.0	3485.0	3440.0	3387.0	3318.0	0.0
Line Amperes:	10.9	14.3	18.6	23.6	29.6	36.8	27.2

Performance Graph at 230V, 60Hz, 5.0HP Typical performance - Not guaranteed values

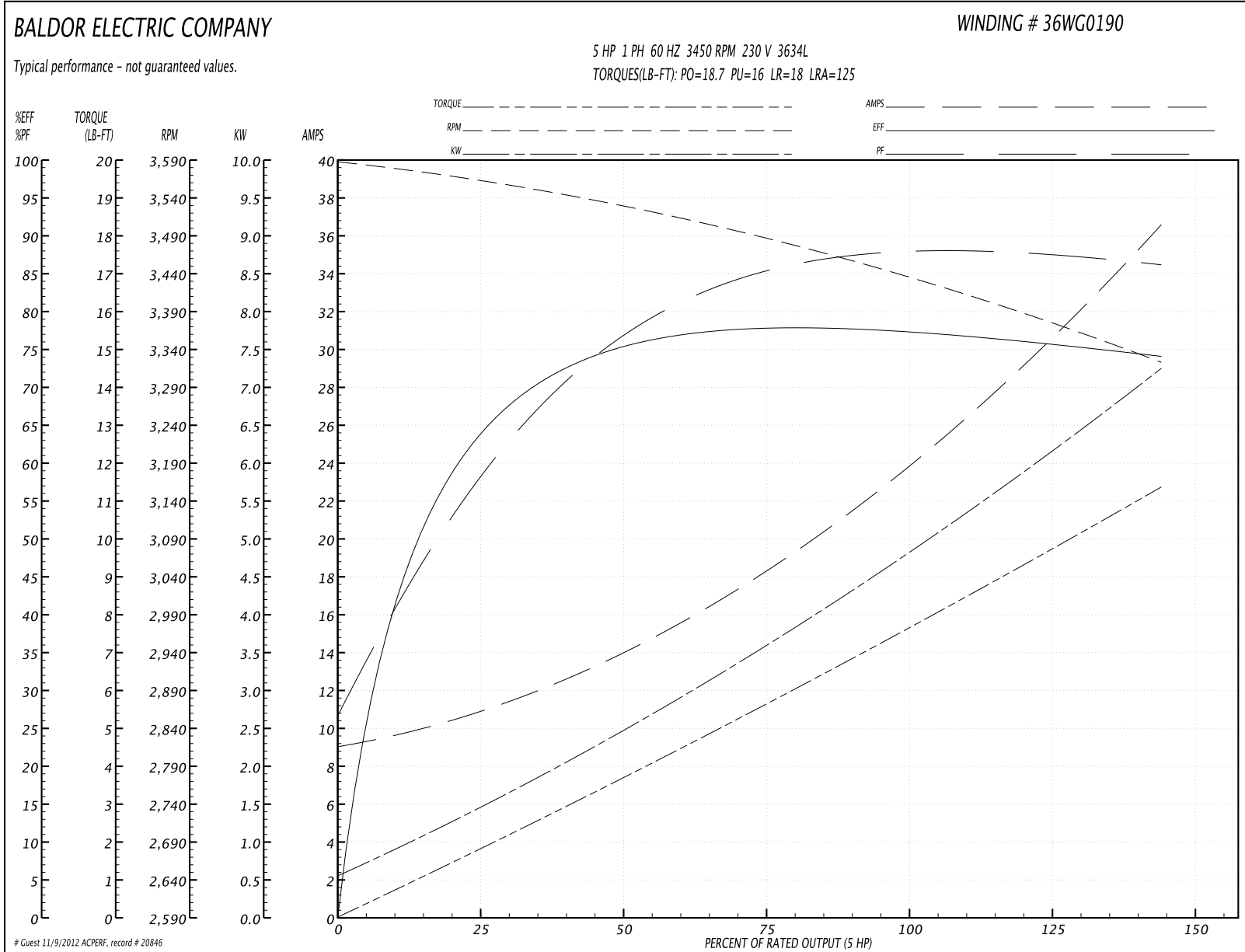

36LYE775

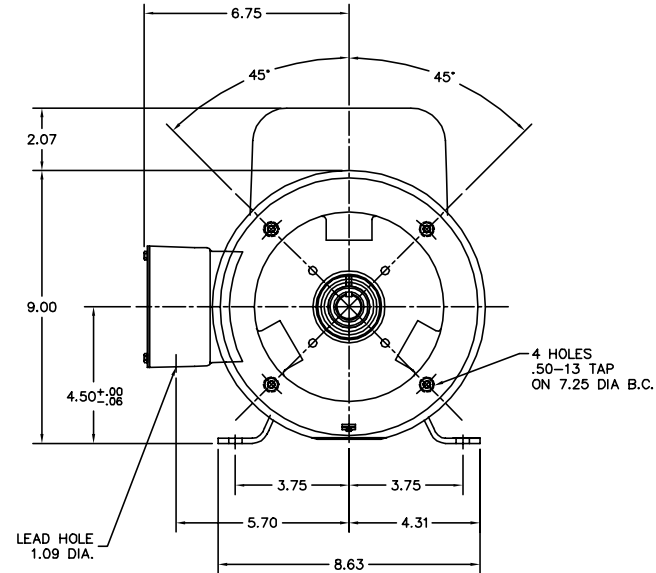
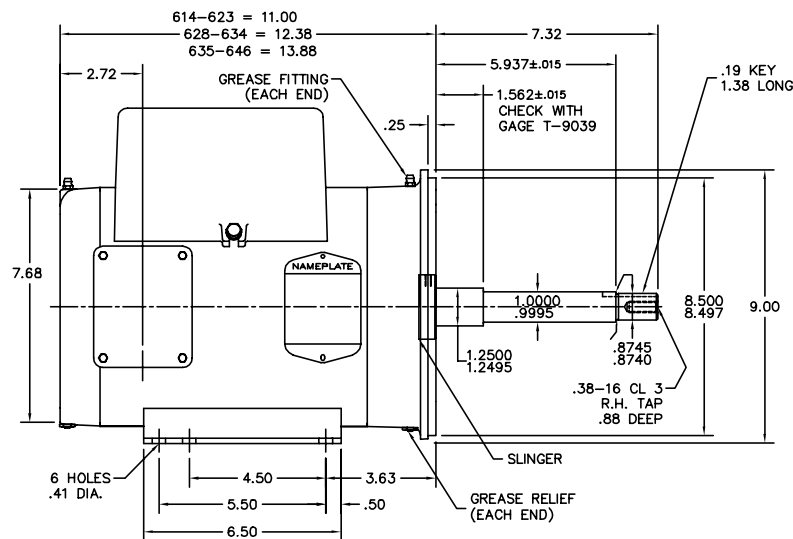

CUSTOMER IS RESPONSIBLE FOR DETERMINING THAT MOTOR PERFORMANCE IS SUITABLE IN THE APPLICATION.

REV. DESC:	CHG'D INT FAN SHOVE TO .75"
REV. LTR:	J BY: RMP REVISED: 15:03:04 06/28/2004 TDR: 336565
FILE:	AAA00013549 REF: 36LYE775
MTL:	-

**BALDOR ELECTRIC Co.**  
 HORZ 182-4TCZ OPEN 36L-LC W/SCREEN

36LYE775

CD0017A01

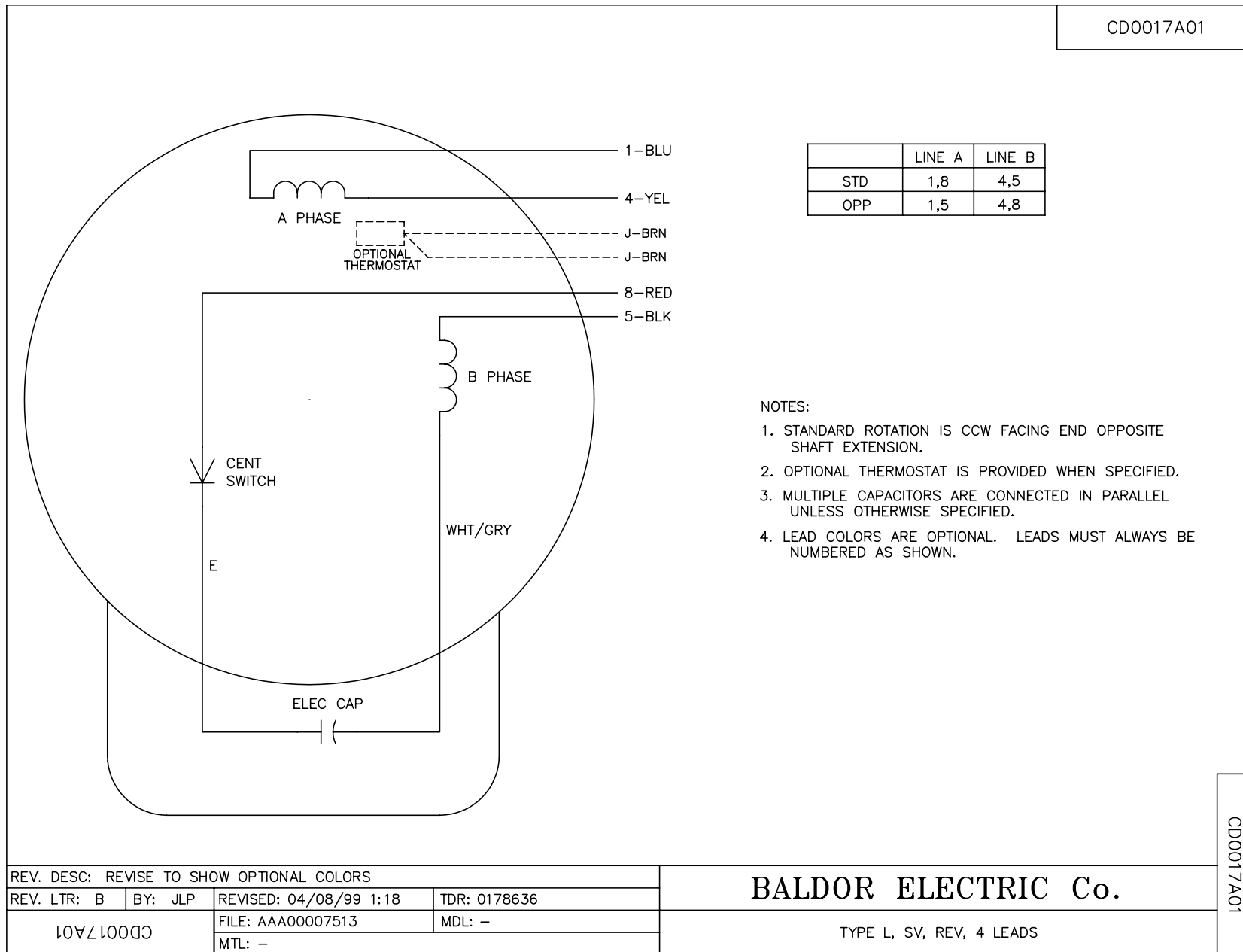

REV. DESC: REVISE TO SHOW OPTIONAL COLORS			
REV. LTR: B	BY: JLP	REVISED: 04/08/99 1:18	TDR: 0178636
10VZ10000		FILE: AAA00007513	MDL: -
CD0017A01		MTL: -	

**BALDOR ELECTRIC Co.**

TYPE L, SV, REV, 4 LEADS

CD0017A01