

BALDOR® • ***RELIANCE***

Product Information Packet

ZDFRPM25404

40HP, 1750RPM,3PH,60HZ,2586,TEFC,FOOT

Part Detail			
Model Number:	ZDFRPM25404	Environment:	General Purpose
Voltage:	460	HP:	40
RPM:	1780/3560	Efficiency:	NA
Phase:	3	Frequency:	N/A
Inverter Duty:	Y	Enclosure:	TEFC
Frame Group:	250	Frame Size:	FL2586Z
Features:	RPM AC	Mounting:	Foot Mounted
Service Factor:	1	Enclosure Group:	TEFC
Weight:	0	Price Symbol:	E2
Speed Range:		Insulation Class:	H
Nema Design:		Encl. Enhancement:	
Catalog Page:	B-196	Dimension Sheet:	617581-1
Connection Diagram:	422927-1	Electric Design:	L3271A
Single HP:	40	Get Notes:	RPM AC
Revision:		Instruction Manual:	
Application:	Variable Speed-V*S	Epact:	
Scaled Drawing:		Obsolete:	N
Last Data Source:	RGG,MADD	Bearing Type:	
Electrical Type:		Mounting Pos.:	
Ambient:	40	Duty:	
Amps:		Nominal Eff.:	
Kva Code:		Power Factor:	
Poles:	00	Literature:	

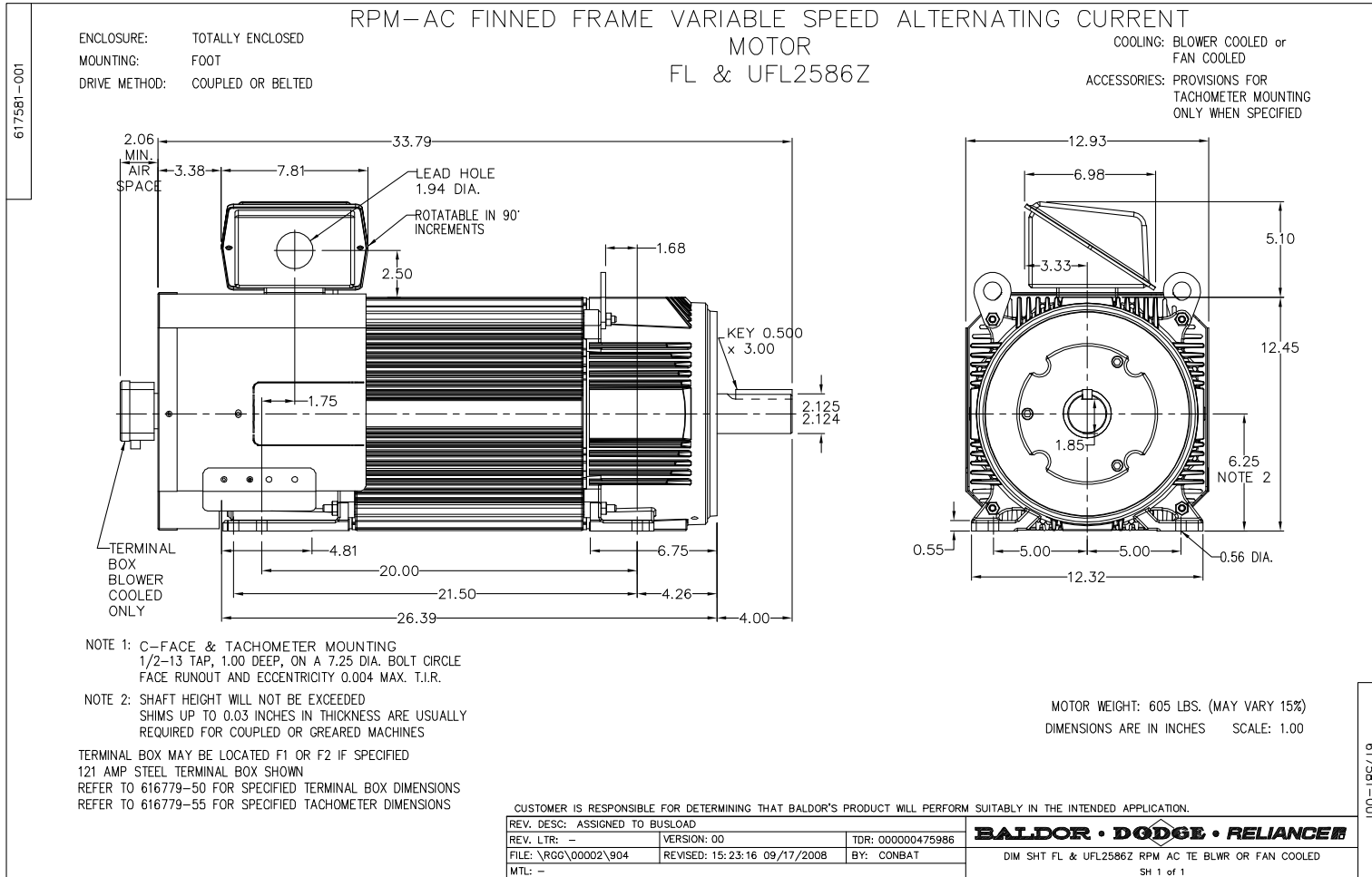

422927-001

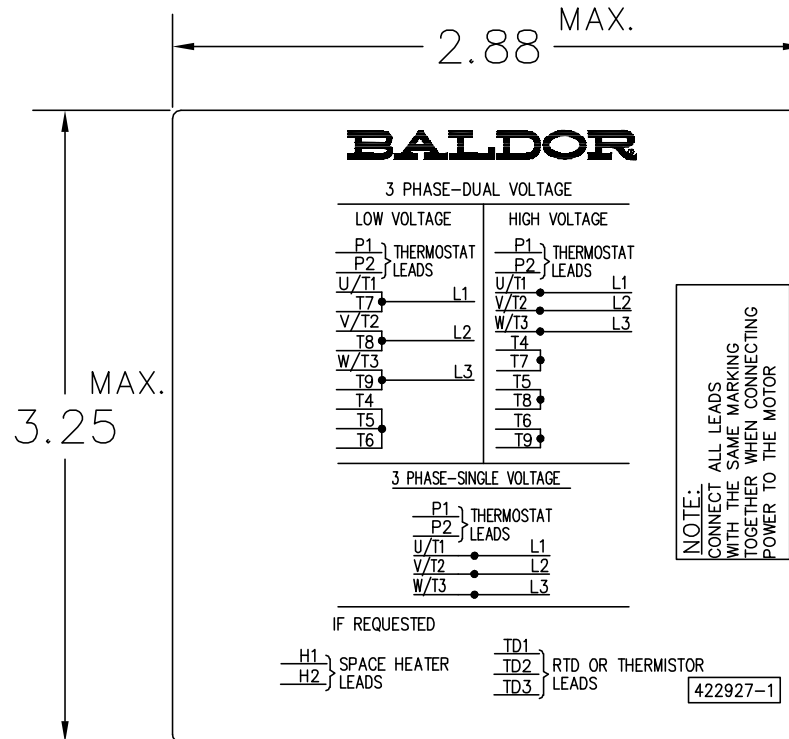

NOTE:
DATA TO BE SIZED
SO THAT IT FITS INTO
MATERIAL DECAL
DIMENSIONS. MAKE
LETTERS & NUMBERS
AS LARGE AS POSSIBLE.

MATERIAL: CERAMATIC DGF-P4
PERMA GRIP ADHESIVE

ALL LETTERS, NUMBERS
AND LINES TO BE BLACK
ON GOLD BACKGROUND.

NOTE:
CONNECT ALL LEADS
WITH THE SAME MARKING
TOGETHER WHEN CONNECTING
POWER TO THE MOTOR

422927-001

REV. DESC: CHANGE LOGO TO BALDOR		
REV. LTR: A	VERSION: 01	TDR: 000000556744
FILE: \RGG\00000\203	REVISED: 02:51:59 09/02/2010	
MTL: -	BY: RGGWT	

BALDOR

EXTERNAL CONNECTION LABEL
SH 1 of 1

REL. S.O.	-	VOLTS	460	ENCLOSURE	TEFC	WYE CONN EQ CKT OHMS PER PHASE (AT BASE RATING, 25 °C)
FRAME	FL2586	AMPS	51	MAX SAFE RPM	5000	
HP	40	DUTY	CONT	IM (AMPS)	25	R1 .0669 X1 .338
BASE SPEED	1780	S.F.	1.0	P.F.@NL/FL	.049/.804	R2 .0458 X2 .610
PHASE/HERTZ	3/60	AMB °C/INSUL	40/H	WK ² (LB-FT ²)	4.9	XM 10.5

RATED FULL LOAD DATA

	RPM	HP	TORQUE LB-FT	FUND VOLTS	FREQ-HZ	AMPS
BASE SPEED	1781	40.0	118	460	60	50.6
MAX SPEED	3560	40.0	59	460	120	46.8
MIN SPEED	0	0	118	9.71	.621	50.6

LOAD PERFORMANCE AT BASE SPEED

	RPM	HP	TORQUE LB-FT	FUND VOLTS	FREQ-HZ	AMPS
NO LOAD	1800	0	0	460	60	24.5
1/4	1795	10.0	29	460	60	27.5
1/2	1791	20.0	59	460	60	33.4
3/4	1786	30.0	88	460	60	41.4
FULL LOAD	1781	40.0	118	460	60	50.6
O/L	1760	79.1	236	460	60	92.0

BLOWER DATA	VOLTS	PH/HZ	FL AMPS	LR AMPS	FRAME	CFM

REMARKS: TYPICAL DATA
CORRELATED DATA

	DR. BY	B. GRANT	A-C MOTOR PERFORMANCE DATA
	CK. BY	T. CUER	
	APP. BY	5-9-06	
	DATE	5-9-06	

L3271A
ISSUE DATE 5-9-06

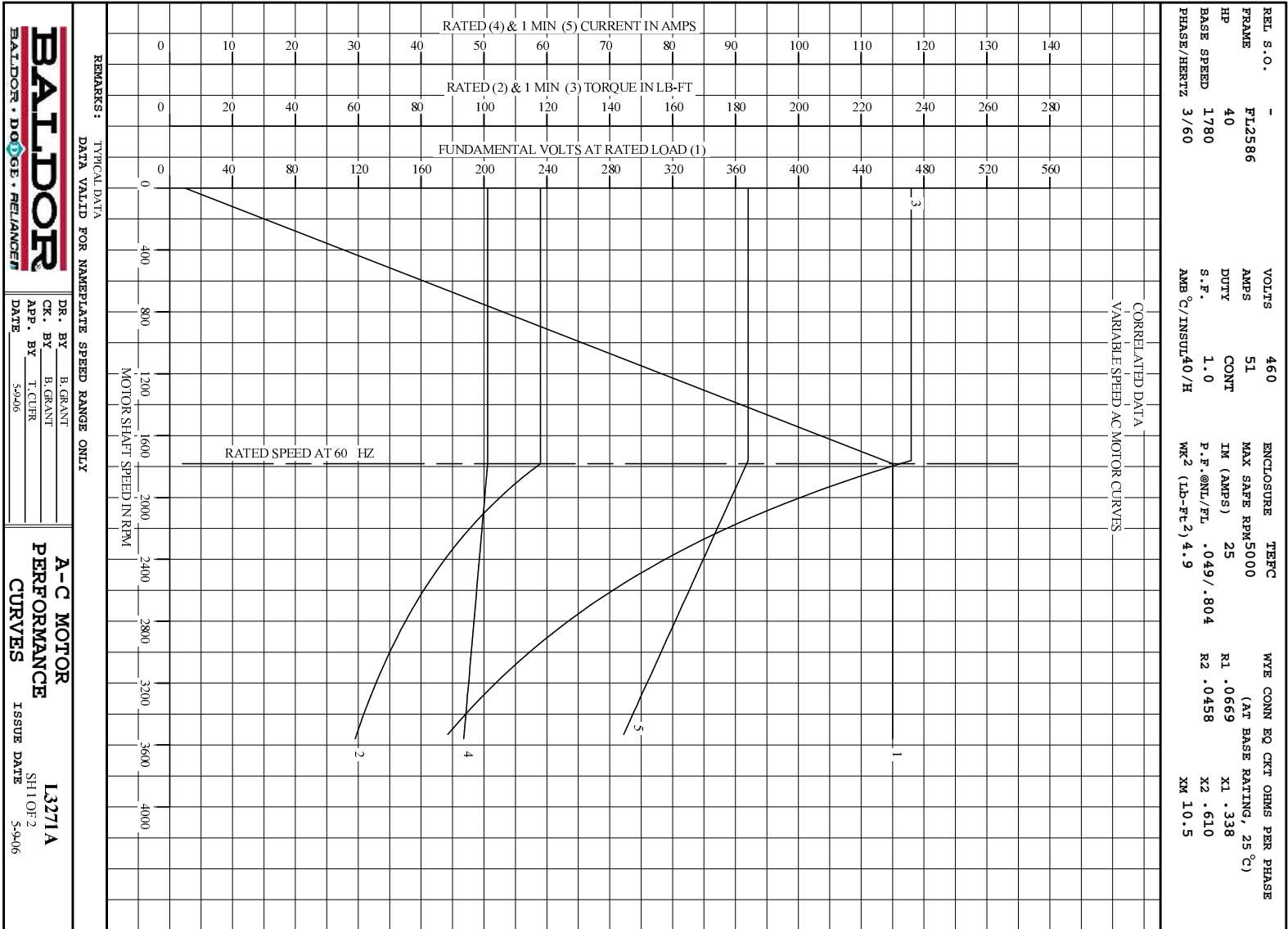

REMARKS: TYPICAL DATA
 DATA VALID FOR NAMEPLATE SPEED RANGE ONLY

BALDOR BALDOR • DOUGLASS • RELIANCE	DR. BY B. GRANT CK. BY B. GRANT APP. BY T. CURR DATE 5-9-06
---	--

A-C MOTOR PERFORMANCE CURVES	L3271A SH 1 OF 2 ISSUE DATE 5-9-06
-------------------------------------	---

REL S.O.	-	VOLTS	460	ENCLOSURE	TEFC	WYE CONN EQ CKT OHMS PER PHASE
FRAME	FL2586	AMPS	51	MAX SAFE RPM	5000	(AT BASE RATING, 25 °C)
HP	40	DUTY	CONT	IM (AMPS)	25	R1 .0669 X1 .338
BASE SPEED	1780	S.F.	1.0	P.F.@NL/FL	.049/.804	R2 .0458 X2 .610
PHASE/HERTZ	3/60	AMB C/INSUL	40/H	WK ² (LB-FT ²)	4.9	XM 10.5

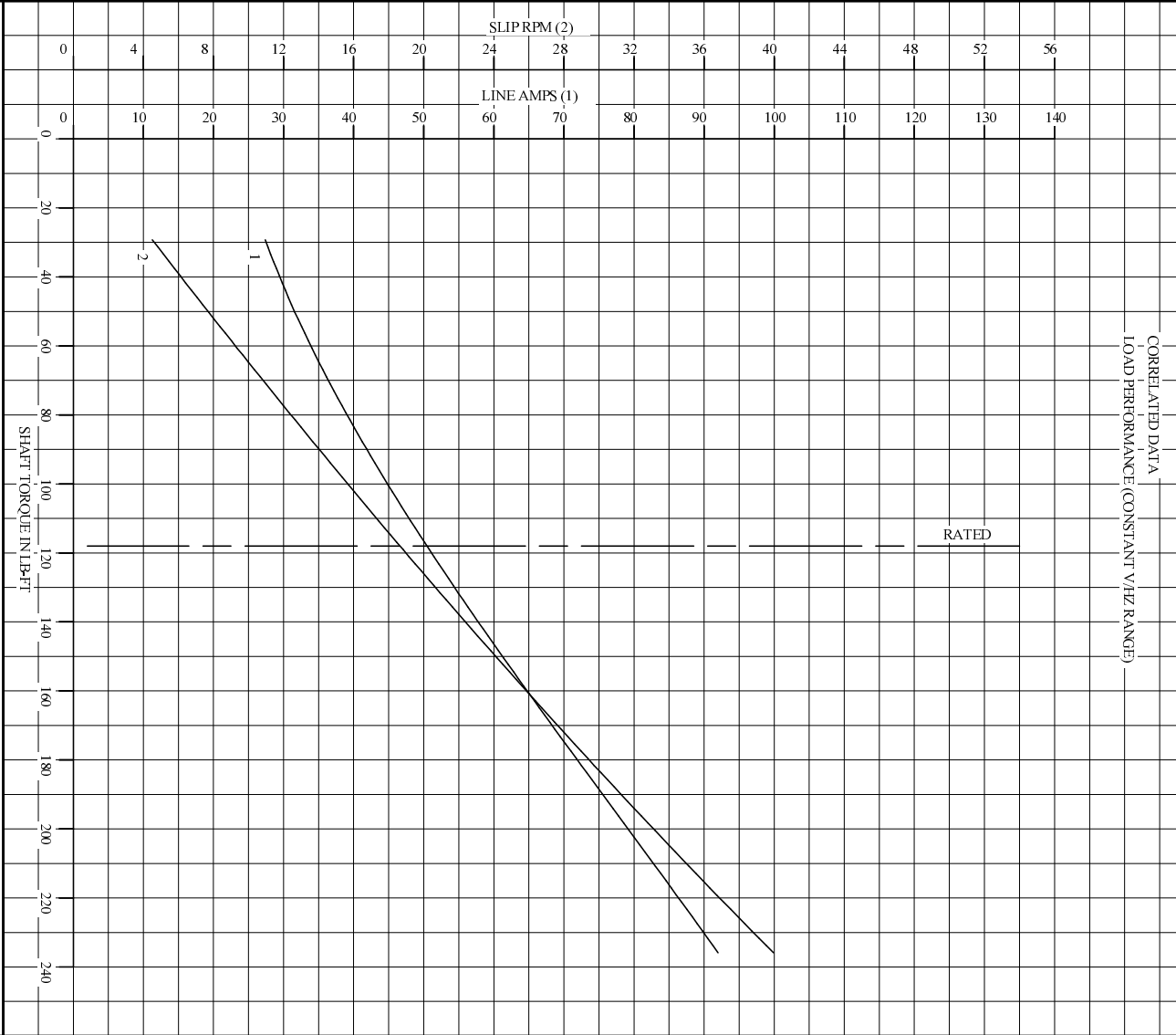

REMARKS: TYPICAL DATA
DATA VALID FOR NAMEPLATE SPEED RANGE ONLY

BALDOR	DR. BY	B. GRANT
• DOUG • RELIANCE	CK. BY	B. GRANT
	APP. BY	T. CURR
	DATE	5-9-06

A-C MOTOR PERFORMANCE CURVES

L3271A
SH20F2
ISSUE DATE 5-9-06