



825 Class Night Star Solar LED Beacon

The 825 Class Night Star Solar LED Beacon is a self-contained, high-performance, low-maintenance and easy-to-install solar-powered light source suitable for various applications and industrial environments. All of the components are incorporated within a compact, stand-alone unit that provides a clean, renewable and reliable energy source with a minimal impact on the environment. The 825 also features a replaceable and recyclable battery pack that extends the service life beyond five years, reducing the total cost of ownership and resulting in significant cost savings over the life of the product. The base and lens are made from a UV resistant, polycarbonate/polysilixane co-polymer with double O-ring sealing and a waterproof vent. The unit is available in blue, red, amber, green and white.

The 825 Class Night Star Solar LED Beacon is the first solar product to incorporate intelligent deployment location settings that allow the 825 to be tuned to its location, protecting it against improper configuration. A microprocessor Energy Management System (EMS) monitors and adapts the brightness to environmental conditions for consistent operation and long life under the toughest conditions.

Easy configuration and programming options include an on-board user interface and Device Manager software through USB connection. The 825 is also available in a version that features an optional external on/off switch.

825 Class Night Star Solar LED Beacon Features

- Dusk-to-dawn operation
- Replaceable and recyclable battery pack
- Intuitive on-board user interface
- Intelligent deployment location settings to protect against improper configuration
- Optional external on/off switch
- -45°F to 124°F (-43°C to 51°C) operating temperature
- IP 68
- Flash or steady output
- Enclosure Class 6P
- Over 250 flash patterns

825 Class Night Star Solar LED Beacons

Description	Type	Cat. No.	Base Color	LED Colors	Candela Output	Replacement Battery Pack
Solar LED Beacon	No Switch	825SOLAR*	Gray	Blue, Red, Amber Green, White	Color dependent. See chart below.	825BATTPK
	With Switch	825SOLAR*SW	Gray	Blue, Red, Amber Green, White	Color dependent. See chart below.	825BATTPK

*Letter in this position designates LED color: B - Blue, R - Red, A - Amber, G - Green, W - White

Accessories

Cat. No.	Description
825BIRD	Bird Deterrent (1 ships with each light)
825REPLKITSW	Bottom Cover Replacement Kit (w/switch)
825REPLKIT	Bottom Cover Replacement Kit (w/o switch)
825BATTPK	Battery Pack
825BATTCHG	Battery Charger
825BCTOOL	Button Cover Removal Tool
825USB	USB Cable for 825 Solar, A-type plug to Mini-B-type plug, 2m long
825DVM	825 Class Device Manager Software CD
825MP	825 Class Mounting Plate
825STBK	825 Class Standard Bolt Kit
825SECBK	825 Class Security Bolt Kit
825FRC	825 NS 1.5" Diameter Frangible Coupling
825FF	825 NS 1.5" Diameter Floor Flange
825FRC21	825 NS 2" to 1" Diameter Frangible Coupling
825FF2	825 NS 2" Floor Flange
825FMK	825 Fence Mounting Kit

Candela Output

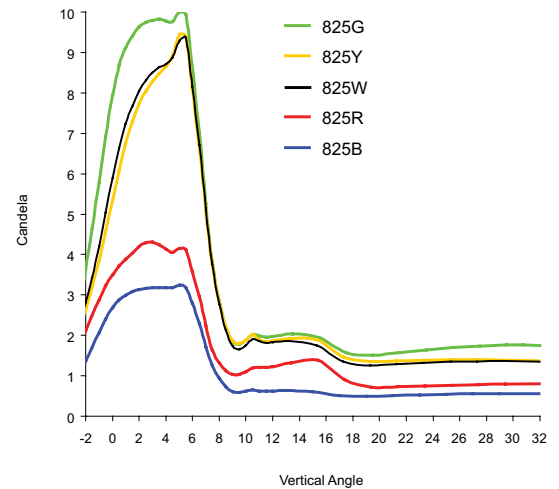

Dimensional Drawings

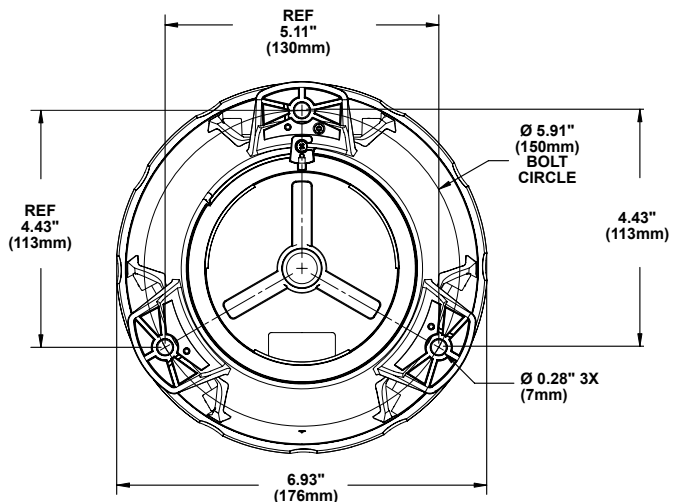
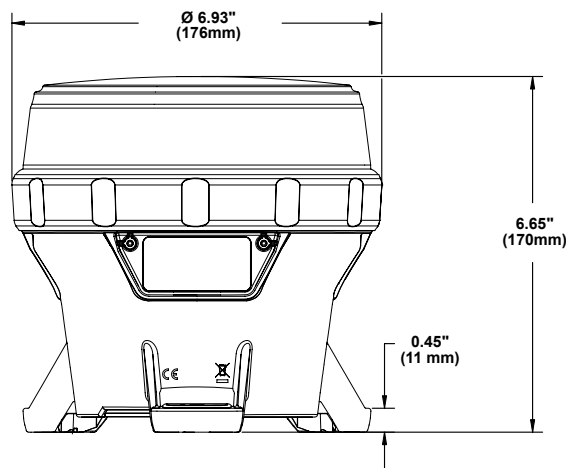

Agency Approvals



41 Woodford Avenue
Plainville, CT 06062
1.800.336.4206
www.edwardssignaling.com

© Copyright 2011 Edwards Signaling

Data Sheet ES001-0116 Issue 1
Not to be used for installation purposes.
Page 2 of 2